

# Operating & Maintenance Manual

## Alert-3 LCD Alarm v2.7

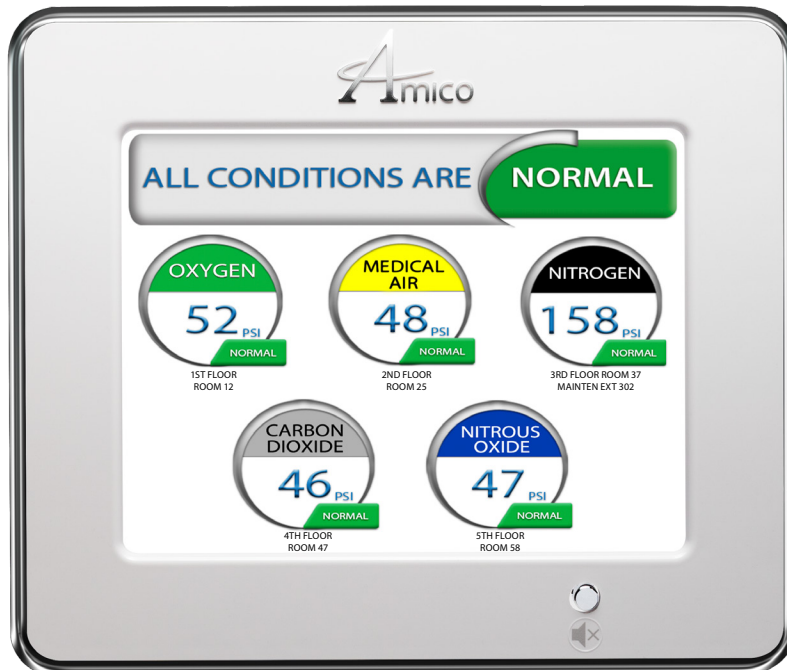

# Contents

<b>User Responsibility</b>	<b>4</b>
<b>Introduction</b>	<b>4</b>
<b>Features</b>	<b>5</b>
<b>Description of the Alarm</b>	<b>5</b>
Shipment Details	5
The Alarm Back Box	5
The Frame Assembly	5
<b>Description of Modules</b>	<b>6</b>
System Power Supply	6
LCD Module	6
Sensor Module	6
<b>Installation Guide</b>	<b>7 - 11</b>
The Alarm Back Box	7
For Local Sensor Only	7
Standing Pressure Test	7
Sensor	7 - 8
Local	7
Remote	8
Frame Assembly	8
System Power Supply	9
Sensor Module	9 - 10
Gas Display	9
Local	10
Remote	10
LCD Display Module	10
LCD Display Setup	11
Closing the Frame Assembly	11
<b>Programming Gas Locations</b>	<b>12-15</b>
Clear/Erase Programming Gas Location Text	15
<b>Model Numbers</b>	<b>16</b>
<b>Spare Part Numbers</b>	<b>17 - 18</b>
Sensors	17
DISS Kits	17
Accessories/Misc.	17
Demand Check Valves	18
Retro-fit Parts	18
<b>Dimensions</b>	<b>19</b>

# Contents

<b>Troubleshooting</b>	<b>20 - 21</b>
<b>Appendix A</b>	<b>22</b>
Wiring Diagram: LCD Board	
<b>Appendix B</b>	<b>23</b>
Wiring Diagram: Auto-Switch Power Supply	
<b>Appendix C</b>	<b>24</b>
Wiring Diagram: LCD Display Board - Alarm Buzzer	
<b>Appendix D</b>	<b>25</b>
Wiring Diagram: LCD Display Board - Local Sensor	
<b>Appendix E</b>	<b>26</b>
Wiring Diagram: LCD Display Board - Remote Sensor	
<b>Appendix F</b>	<b>27</b>
Wiring Diagram: LCD Display Board - Master Module	
<b>Appendix G</b>	<b>28</b>
Technical Specifications	
<b>Appendix H</b>	<b>29</b>
Wiring	

# User Responsibility

The information contained in this Installation, Operation and Maintenance Manual pertains only to the Alert-3 microprocessor based digital LCD Alarm. This product will perform as described in this manual when assembled, operated, maintained and serviced in accordance with the installation instructions provided.

The alarm must be checked periodically. Parts that are broken, missing, worn, distorted or contaminated must be replaced immediately. Should such repair or replacement become necessary, please contact Amico Corporation or their distributors.

Alarms should not be altered without prior written or verbal approval from Amico Corporation or a factory trained service technician. Failure to comply will void all warranty on the alarm.

Statements in this manual preceded by the words WARNING, CAUTION, DANGER and NOTE are of special significance. Please read these sections carefully.

**NOTE:** Amico strongly recommends that alarms be checked annually by qualified staff.



**WARNING:** DENOTES STEPS WHICH CAN PREVENT INJURY.



**CAUTION:** DENOTES STEPS WHICH CAN PREVENT DAMAGE TO EQUIPMENT.



**DANGER:** DENOTES STEPS WHICH CAN PREVENT ELECTRICAL SHOCK TO EQUIPMENT OR TO PREVENT SERIOUS INJURY AND/OR DEATH.

## Introduction

The Amico Medical Gas LCD Alarm System (Alert-3) incorporates the latest microprocessor based technology for alarm and surveillance systems. The alarm has been designed to provide user flexibility and reliability. This manual shall enable the customer to install, use and maintain the alarm appropriately.

There is one "MUTE" (🔇) or "PUSH TO TEST" button located on the front face of the LCD alarm. The button has two functions: to silence an alarm that has occurred and to view the audible alarm sound level at high and low set points. When an audible alarm is triggered, press the button to silence the alarm. To view the audible alarm sound level at high and low set points, press and hold the button for 20 seconds to display the information on the LCD Alarm screen.

All Gases or Vacuums are displayed on the LCD alarm for clear visibility to facilitate the monitoring function by hospital personnel. Under normal operation, the gas indicator will be in the "GREEN - OK" position. If an alarm condition occurs, a "RED-Alarm" indicator will be displayed and an audible alarm shall be continuous until silenced by pushing the "MUTE" button.

The LCD Alarm can be connected to a "Building Management System" for a generic alarm dry contact fault indicator.

# Features

- Microprocessor based digital LCD and individual microprocessor on each sensor module
- Gas-specific sensors can be mounted locally or remotely, up to a distance of 1000 feet [304.8 m], utilizing a #22 gauge stranded, shielded twisted pair cable ONLY
- DISS gas-specific sensor housed in a tamper-proof enclosure. The Sensor Module is housed in an anodized aluminum and nickel-plated brass enclosure to act as a barrier against any interference
- The Sensor Module is the smallest computer-calibrated temperature-compensated sensor in the industry
- PSI, kPa, inHg, mmHg or BAR display (programmable)
- Self diagnostic circuitry with error display for problem identification
- Very accurate Solid State Pressure piezoresistive transducer
- Dry contact is built in for remote monitoring of the LCD alarm
- Modules are factory mounted on a hinged frame assembly for ease of installation and maintenance
- Field programmable push buttons for adjustment of "HI" and "LOW" set-points
- LCD Alarm available in 1 to 8 gases

## Description of the Alarm

### **SHIPMENT DETAILS**

When you receive an Alert-3 LCD alarm from Amico Corporation, the package will consist of three main sections: the Alarm Back Box, Sensors and the Frame Assembly.

### **THE ALARM BACK BOX**

The Alarm Back Box contains an auto-switchable power supply with an ON/OFF switch, a built-in fuse and terminal blocks (115 to 220 VAC - 50 to 60 Hz). The back box also incorporates the pipe stubs for applications that require locally (in box) mounted sensors.

### **THE FRAME ASSEMBLY**

The Frame Assembly consists of the frame and the LCD board. The hinged frame is designed to swing down from the back box to facilitate installation and servicing of the alarm. This design will reduce installation time and eliminate the risk of improper installation since all the modules are connected and tested at the factory.

# Description of Modules

The Alert-3 LCD Alarm is a high technology microprocessor based module:

## COMMON TO ALL ALARMS

### SYSTEM POWER SUPPLY

The System Power Supply has been pre-installed into the back box assembly. The System Power Supply converts the AC voltage supply to the alarm into two voltages: 5 VDC (regulated) required by the microprocessor hardware and 15 VDC (unregulated) required by the buzzer and the LCD. This unit also contains the main ON/OFF power switch, the transformer, the heat sink, the main fuse and fuse cover, the rectifying circuitry, the terminal blocks and the low voltage DC power cable for connecting this unit to the module. The System Power Supply can be easily removed and reinstalled by unscrewing it from the back box.

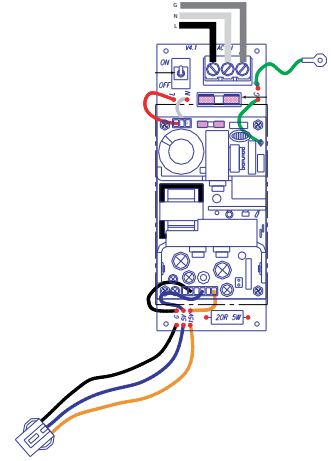

### LCD MODULE

The LCD Module contains the LCD screen, microprocessor, buzzer and the "MUTE" button. The function of the "MUTE" button is to silence an alarm that has occurred. By holding the "MUTE" button for 20 seconds, the module will display the high and low pressure set points. This module also contains a fail-safe relay that de-energizes when the buzzer is activated. This relay can be used with the Amico Remote Buzzer for applications requiring a remote audible alarm, master alarm or a Building Management System.



### SENSOR MODULE

The Sensor Module contains the transducer which converts the source of the pressure/vacuum into a digital signal that is displayed on the LCD alarm. The sensor module shall be housed in an anodized aluminum and nickel-plated brass enclosure to act as a barrier against interference and it is temperature compensated. Each sensor is clearly labeled and color coded for the gas or vacuum being monitored. The sensor module contains a gas-specific DISS fitting to ensure correct connection of the proper sensor to the respective gas. Each sensor has been factory calibrated for the specific gas shown on the sensor housing.



### For Annual Test

- **Reset power to make sure LCD screen lights up**
- **Hold the MUTE button for twenty (20) seconds to display the current low and high set points and the audible alarm. Once the audible alarm stops, the LCD Alarm will go back to normal.**

**NOTE:** Do not press "mute button" while on test mode. If press, it will repeatedly show current set points.

# Installation Guide

## STEP 1: THE ALARM BOX

Install the back-box to the studs of the wall at the desired height. Ensure that the box is securely in place. The mounting brackets are adjustable to suit the thickness of the wall. **MAKE SURE** the box is parallel, squared and flush with the finished wall surface to ensure that the frame assembly will fit properly.

**NOTE:** Make sure to install back box properly. The frame will cover limited wall space.

## STEP 2: FOR LOCAL SENSORS ONLY

If the sensors are to be mounted locally (inside the back box), the pipe stubs must be connected to the pipeline. Using silver-brazing techniques, connect each pipe stub to its appropriate gas or vacuum while ensuring that the bottom of the pipe stub is wrapped with a damp cloth. **BE CAREFUL** not to damage the DISS check-valve by overheating the lower portion of the copper pipe. When the brazing of pipe stubs has been completed, the system can be pressure tested.

## STEP 3: STANDING PRESSURE TEST

Perform a standing pressure test on the piping system as per NFPA-99 "Health Care Facilities" or CSA-Z7396.1 "Medical Gas Pipeline Systems". Inspect all joints for leaks and make certain each gas is piped to a correspondingly labeled gas service.

## STEP 4: SENSOR

A: LOCAL (inside the back box)

- i. Locate the gas-specific sensor module to be installed.
- ii. In the back box, there are color coded gas labels located under the DISS Demand Check Valves. Each label identifies where each sensor module is to be placed.
- iii. The sensor module contains a gas-specific DISS fitting. Push the sensor module hex-nut and nipple adapter up into the demand check-valve. With a wrench, tighten the nut so that it makes a good seal.

**NOTE:** PRESSURE ON SENSORS ARE NOT TO EXCEED 250 PSI FOR PRESSURE SENSORS AND 30 INHG FOR VACUUM SENSORS. **MAKE SURE** THAT THERE ARE NO MOISTURE, WATER OR BURS INSIDE THE PIPELINE BEFORE PROCEEDING WITH THE PRESSURE TEST.



Alert-3 sensor operating pressure range:

Mid Pressure	(0 to 99 psi)	-	Oxygen, Medical Air, Nitrous Oxide, Carbon Dioxide
High Pressure	(0 to 249 psi)	-	Nitrogen, Instrument Air
Vacuum	(0 to 30 inHg)	-	Vacuum, WAGD, AGSS



### CAUTION:

1. To protect from static electricity, ensure to discharge body static before installing the Medical Gas Alarm and sensors
2. Do not ground the shield drain wire at sensor or inside alarm panel back box

# Installation Guide

## B: REMOTE (OUTSIDE THE BACK BOX)

- i. Connect a tee (supplied by others) to the pipeline with a 1/4" NPT female connection that will accept the DISS Demand Check Valve.
- ii. Locate the gas-specific sensor module to be installed.
- iii. Thread the DISS Demand Check Valve into the correct gas pipeline.
- iv. The sensor module contains a gas-specific DISS fitting. Push the sensor module hex-nut and nipple adapter into the demand check-valve. With a wrench, tighten the nut so that it makes a good seal.
- v. Marrette in a junction box (supplied by others) the #22 gauge stranded, shielded twisted pair sensor cable to the installation cable (supplied by others).
- vi. In the presence of any electrical, magnetic, radio frequencies, wireless or other interference, cable installation (supplied by others) running from the junction box (supplied by others) to the alarm **MUST** be placed in a metallic conduit.
- vii. It is recommended to have the proper filter installed to prevent water or moisture from coming in. Failed filter will damage the transducer.

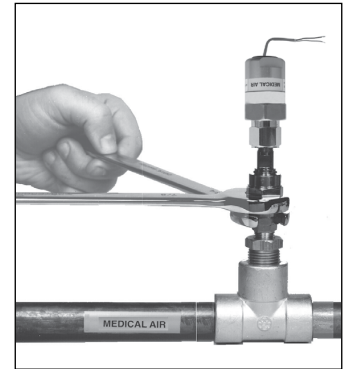

## STEP 5: FRAME ASSEMBLY

- i. Remove the frame assembly from its protective box.
- ii. Remove the side screws from the front frame section (2 screws).
- iii. Attach the LCD screen to the back box assembly by using flat head screws (provided with frame in a plastic bag) to the hinge located on the back box.
- iv. Attach the frame wire with 2 dome head screws (provided with frame in a plastic bag). This will allow the frame assembly and back box to be fastened securely together.



**NOTE:** FRAME ASSEMBLY SHOULD BE CLOSED AND FRAME PLATE SHOULD BE ATTACHED RIGHT AFTER THE INSTALLATION. WHEN INSTALLATION IS COMPLETED AND ALARM IS READY TO USE, PEEL OFF THE LCD SCREEN PROTECTOR.



### CAUTION:

1. The microprocessor circuitry on the ALERT-3 alarm contains sophisticated integrated semiconductors. **DO NOT TOUCH** any of the components on the board. Static discharge can cause the modules to malfunction or become damaged.
2. Keep the shield drain wires as short as possible and taped to prevent from grounding, so they can not touch the front panel circuit board when front panel is closed.
3. Do not use impact screw driver.
4. Warranty void if push button is broken.



# Installation Guide

## STEP 6: SYSTEM POWER SUPPLY



### CAUTION:

TURN OFF POWER SWITCH BEFORE CHANGING ANY MODULES AND/OR DISCONNECTING ANY CABLES. FAILURE TO DO SO CAN CAUSE THE FUSE TO BLOW, DAMAGING THE CIRCUITRY.

- i. Ensure that the ON/OFF switch is in the OFF position.
- ii. Through the top left side of the back box, bring in the AC power wires. Knockouts are provided for making conduit connections to the box. All wiring is to be installed according to local and national codes.
- iii. Connect the AC power to the terminal blocks as shown in the wiring diagram (see Appendix B).



### CAUTION:

- 1. Verify that power has been switched off prior to working on the alarm
- 2. Risk of electric shock. Disconnect power at the circuit breaker before removing power supply shield

## STEP 7: SENSOR MODULE

A: GAS DISPLAY (on screen location)

The location of gases displayed on screen is dependant upon which sensor channel each individual gas is connected to. The display below indicates which sensor channel corresponds to each location the gas will be displayed on the LCD screen.



# Installation Guide

## B: LOCAL (inside the back box)

- i. The sensor module is provided with a 6"-8" [0.1 m - 0.2 m] #22 gauge stranded, shielded and twisted pair cable. One wire is red (positive) and the other wire is black (negative). Connect the wires to the display module as shown in Appendix D. Take the red wire from the sensor and attach it to terminal "Sensor +" on the display module. Take the black wire from the sensor and attach it to terminal "Sensor -". The terminal block on the display module is clearly marked for proper connection of the sensor wires.
- ii. Repeat the above procedures with the remaining sensor modules.

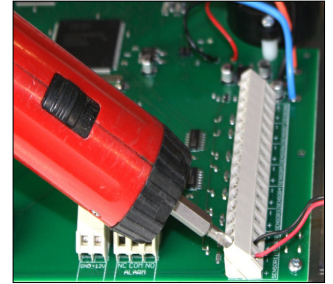

## C: REMOTE (outside the back box)

- i. The sensor module is provided with 6" - 8" [0.1m - 0.2m] #22 gauge stranded, shielded and twisted pair cable. Connect the wires to a junction box (supplied by others) located near the sensor as per the wiring diagram (see Appendix E).
- ii. Connect a #22 gauge stranded, shielded and twisted pair cable ONLY, up to 1000 ft [304.8 m]. Knockouts are provided throughout the alarm back box.
- iii. Connect the red wire from the cable to the terminal on the display module marked "Sensor +". Connect the black wire to terminal "Sensor -" as shown in the wiring diagram (see Appendix E).
- iv. Repeat the above procedures with the remaining sensor modules using the wiring diagram.

### NOTE:

- When remote sensors are used, ONLY a #22 gauge stranded, shielded twisted pair cable must be used (BELDEN #8451 or equivalent, supplied by others).
- Do not ground the shield drain wire at sensor or inside the alarm panel back box

## STEP 8: LCD DISPLAY MODULE

If the dry contacts for a generic alarm is to be used for remote monitoring, connect the wires to the appropriate terminals: COM (Common), NO (Normally Open) or NC (Normally Closed), using the diagram in **Appendix A**.

See **Appendix G** for contact rating.

Once the sensors are connected and the power has been switched on, use the following steps to setup the LCD Alarm.

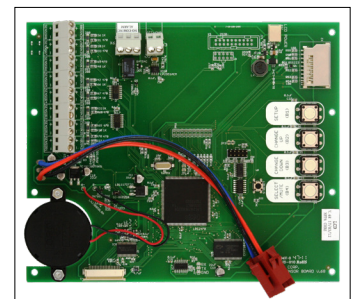

# Installation Guide

## STEP 9: LCD DISPLAY SETUP

- i. Press the SETUP button (B1) and press the SELECT button (B4)
- ii. Volume control: 90, 80, 70, 60 – press the CHANGE UP/DOWN button to change the alarm sound level
- iii. Press SELECT for LCD brightness and press the CHANGE UP/DOWN button to change the LCD brightness
- iv. Press the SELECT button (B4)

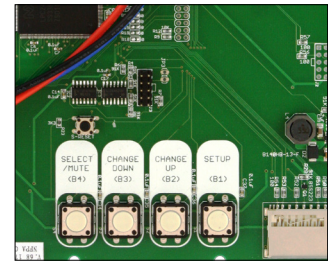

\* The following should be displayed.

*SENSOR: 1*

*SENSOR TYPE: show the gas (example: NITROUS OXIDE)*

*UNITS: PSI (to change to kPA, Bar, inHg, mmHg: press button CHANGE DOWN/UP then press SELECT)*

*LOW ALARM: 40 (to change: press button CHANGE DOWN/UP then press SELECT)*

*HIGH ALARM: 60 (to change: press button CHANGE DOWN/UP then press SELECT)*

*CURRENT PRESSURE: displays exact pressure for the line*

*CURRENT OFF SET: to re-calibrate pressure reading press button CHANGE DOWN/UP then press SELECT*

- v. Repeat steps until all sensors are scanned and data is saved. Next it will show SETUP COMPLETE.

\*All gases should now be displayed. If any errors occur, repeat the steps above.

## NOTE:

- Hold the “MUTE” button for twenty (20) seconds to display current low and high set points and the audible alarm. Once the audible alarm stops, the LCD Alarm will go back to normal. Do not press “mute button” while on test mode. If press, it will repeatedly show current set points
- Press the Setup button (B1) in order to make corrections/go back.

## STEP 10: CLOSING THE FRAME ASSEMBLY

- i. Close the frame panel by tightening the screws found on the frame panel to the back box. Ensure that the screws are securely fastened to keep the LCD Alarm closed.
- ii. Carefully place the front frame over the frame panel. Screw in the screws that were removed in **Step 5, part ii**. The alarm shall now be ready for use.

**NOTE:** IT IS RECOMMENDED TO IMMEDIATELY ATTACH THE FRAME ON TO THE FRAME ASSEMBLY TO PREVENT THE SCREEN AND PUSH BUTTON FROM DAMAGING.



## CAUTION:

1. To protect from static electricity, ensure to discharge body static before installing the Medical Gas Alarm and sensors.
2. Do not use impact screw driver.
3. Warranty void if push button is broken.

# Programming Gas Locations

The following is the recommended hardware and software for optimum program gas location operation:



PC or laptop



Notepad program

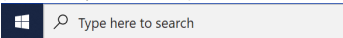

SDHC memory card  
(SD card reader is required)

1. Locate the **Notepad** program by clicking on the Search Bar found at the lower left corner of your screen right next to the Windows button. 
2. Type in "Notepad" on the search bar and press "Enter", a blank **Notepad** file will pop up.
3. Use the **Notepad** program to enter information for gas locations. Each line can hold up to a **maximum of 16 characters**. (**Notepad** is a generic text editor included with all versions of Microsoft Windows)
4. Two lines may be used per individual gas.
5. The order of the text must go in order of the gas; meaning the first two lines of text shall represent the 1st gas location, the next two lines of text shall represent the 2nd gas location, and so forth.
  - Please refer to the diagram in the Installation Guide under section 7a (see pg. 9) to determine gas location on the LCD Alarm screen.
6. Once all the text has been entered, save the file onto the SDHC Card with the file name: **location (.txt)**.
7. Insert the SDHC Card into the SD Card Slot on the LCD Alarm board (Refer to Appendix A).
8. While the LCD Alarm is on, press and release the **RESET** button, then quickly press and hold the **SETUP** button (**B1**) immediately until the information from the file saved on the SDHC Card (**location.txt**) appears on the LCD Alarm Screen.
  - If the gas location text does not appear on the screen, repeat step #6. If the problem persists, contact Amico Corporation for further assistance.
9. Once the text is visible on the LCD Alarm, leave the SDHC Card in the slot for **approximately 1 minute** in order for the information to be completely uploaded onto the alarm, and then proceed to remove the card.
10. Once the card has been removed, restart the LCD Alarm to ensure that the locations have been saved onto the LCD Alarm.

## NOTE:

- Only capital letters, numbers and spaces will be displayed on the screen. Small caps, symbols and special characters cannot be displayed.
- Programming of the gas location is only available for V864 and up. If gas location is required, a new LCD frame assembly is required (part number see pg. 17).
- An SDHC memory card is not provided with the device.

# Programming Gas Locations

## PROGRAMMING GAS LOCATIONS FOR 6 GAS

```
location - Notepad
File Edit Format View Help
1ST FLOOR
ROOM 12
2ND FLOOR
ROOM 25
3RD FLOOR ROOM37
MAINTEN EXT 302
4TH FLOOR
ROOM 47
5TH FLOOR
ROOM 58
6TH FLOOR ROOM65
ENGINEER EXT 225
```

Notepad File

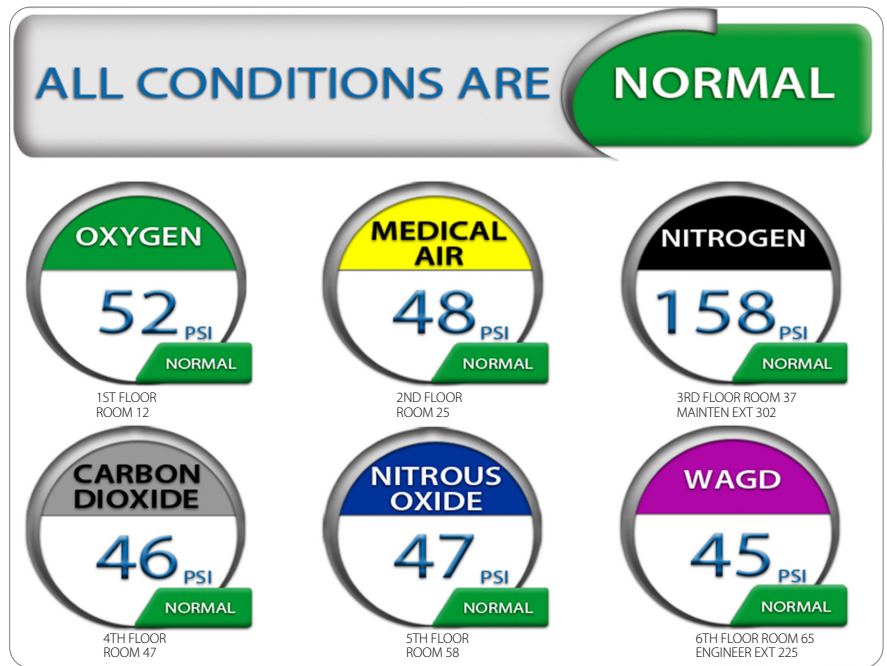

Updated Display on LCD Alarm

## PROGRAMMING GAS LOCATIONS FOR 4 GASES OUT OF 6 GAS

```
location - Notepad
File Edit Format View Help
1ST FLOOR
ROOM 12
3RD FLOOR ROOM37
MAINTEN EXT 302
4TH FLOOR
ROOM 47
6TH FLOOR ROOM65
ENGINEER EXT 225
```

Skip two lines

Notepad File

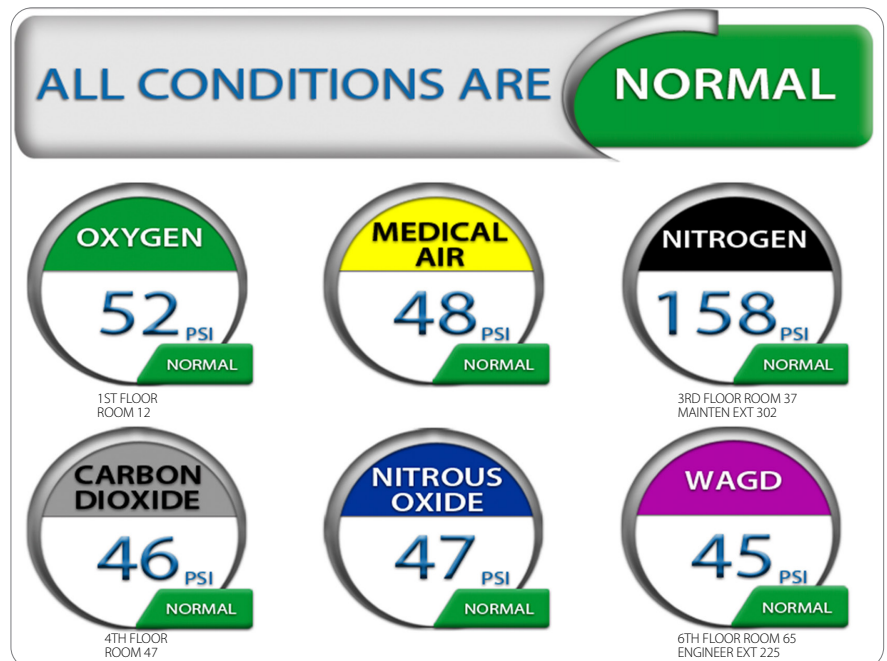

Updated Display on LCD Alarm

# Programming Gas Locations

## PROGRAMMING GAS LOCATIONS TO SKIP LINES

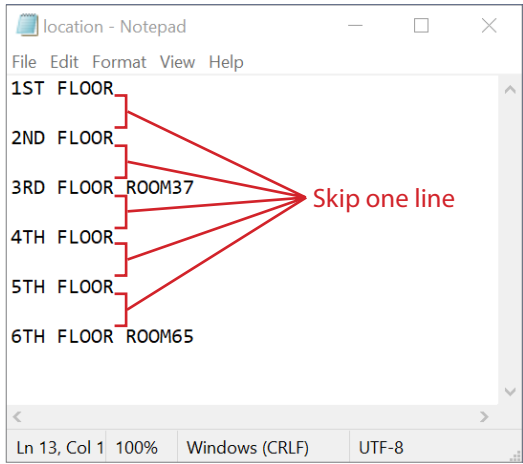

Notepad File

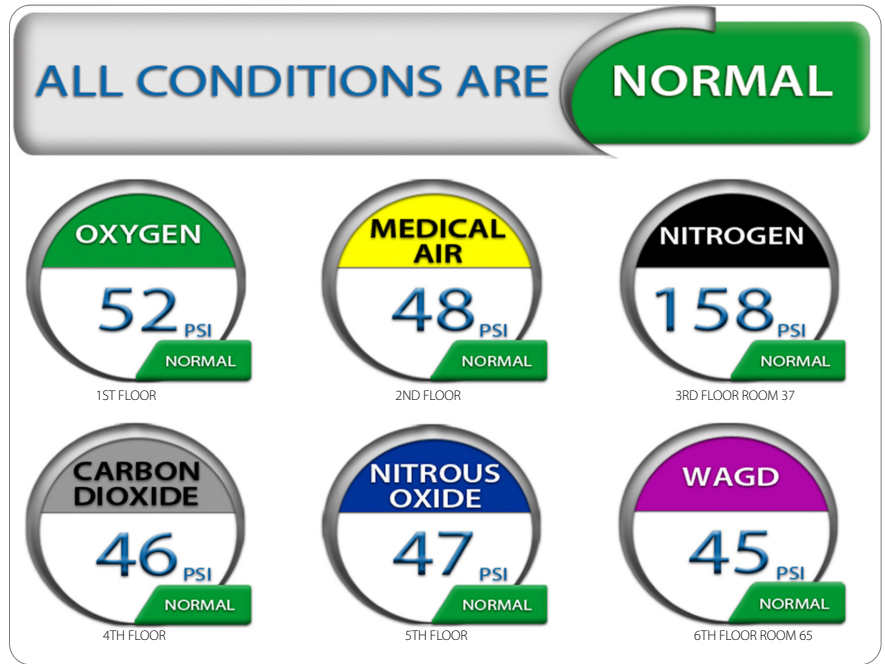

Updated Display on LCD Alarm

## PROGRAMMING GAS LOCATIONS TO SKIP LINES

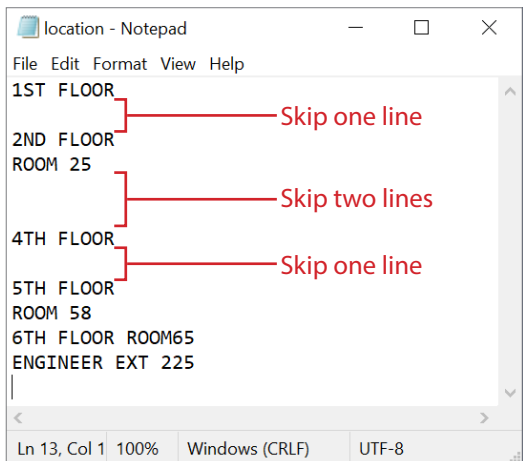

Notepad File

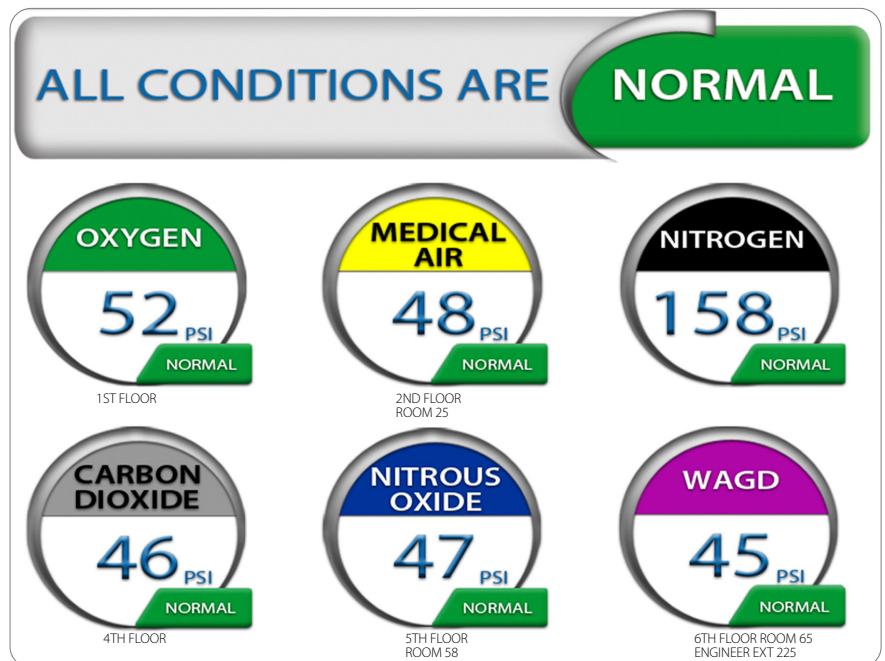

Updated Display on LCD Alarm

# Programming Gas Locations

## CLEAR/ERASE PROGRAMMING GAS LOCATION TEXT

While the LCD Alarm is on, press and release the **RESET Button**, then quickly press and hold the **SETUP Button (B1)** immediately until the information disappears on the LCD Alarm Screen.

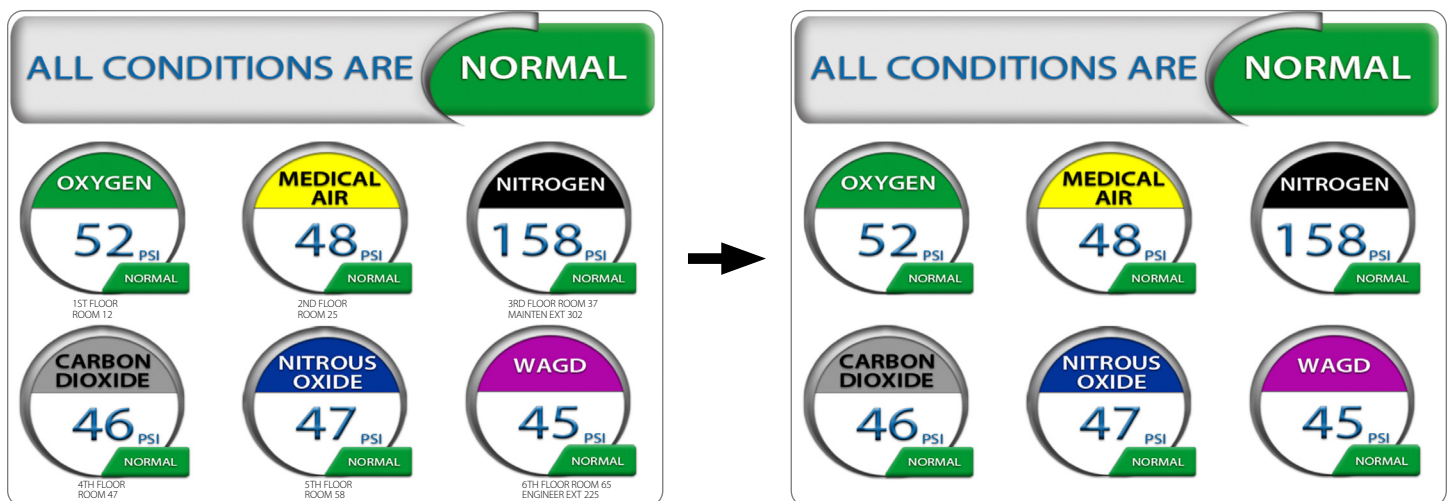
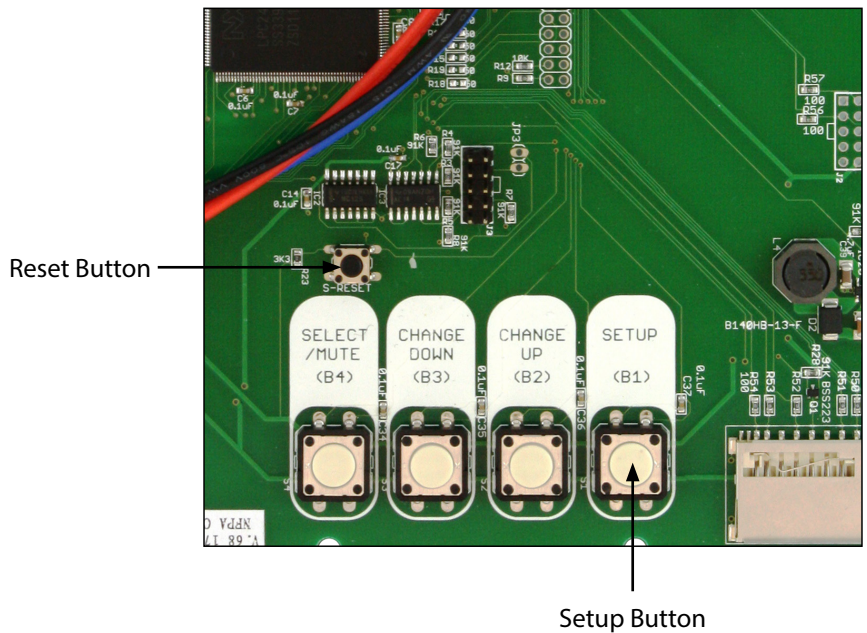

**NOTE:** A SD Card is not needed for this process.

# Model Numbers

## LCD ALARM

### A3AR-L-XXXXXXXX

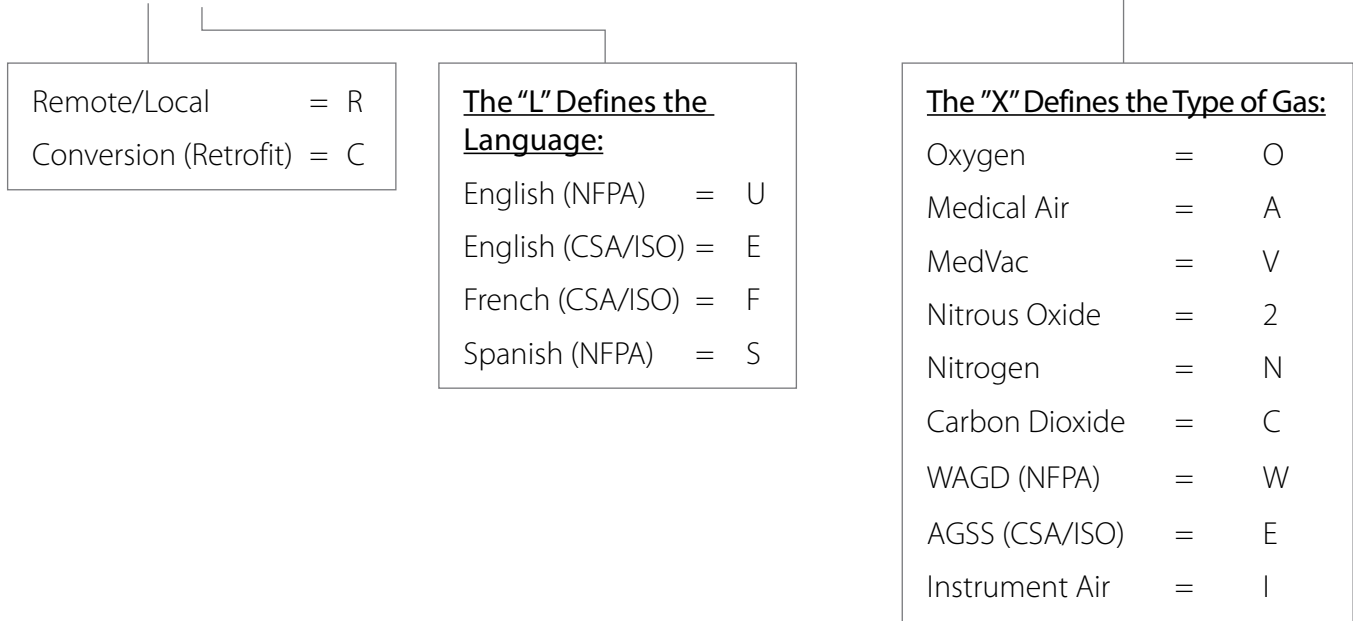

## ALERT-3 SENSOR MODULE

### A3P-SENS-L-GAS

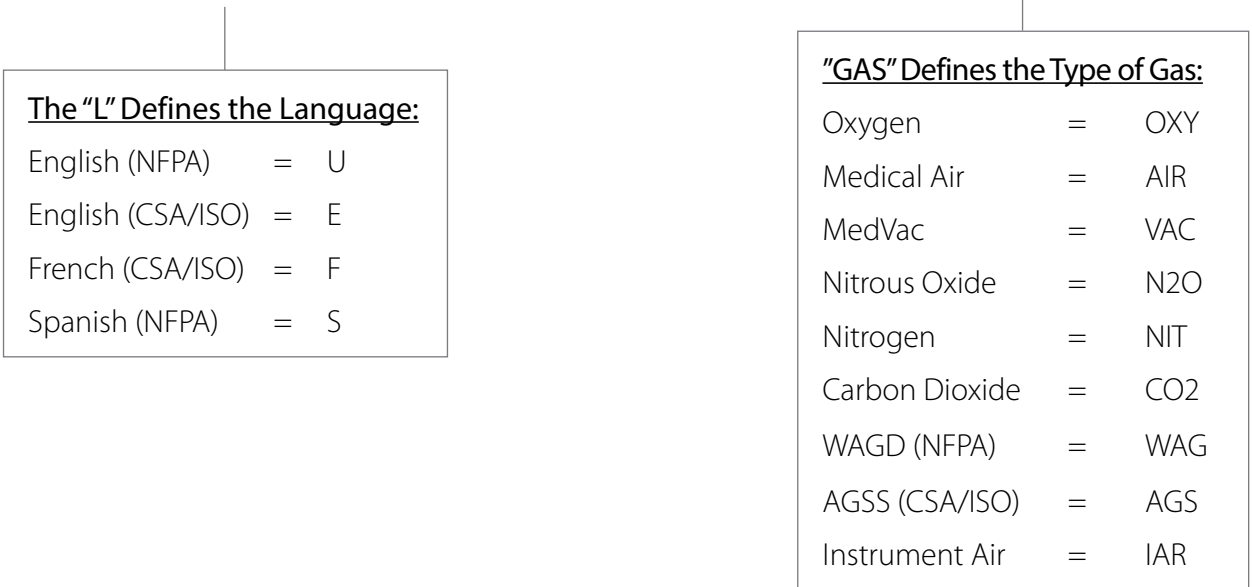

**NOTE:** EACH ALERT-3 SENSOR COMES WITH AN A2P-PIPE



# Spare Part Numbers

## SENSORS

Model Number	Description
A3P-SENS-E-AIR	Sensor Module ISO-AIR Eng. Alert-3
A3P-SENS-E-CO2	Sensor Module ISO/USA-CO2 Eng. Alert-3
A3P-SENS-E-AGS	Sensor Module ISO-AGS Eng. Alert-3
A3P-SENS-E-N2O	Sensor Module ISO/USA-N2O Eng. Alert-3
A3P-SENS-E-NIT	Sensor Module ISO/USA-NIT Eng. Alert-3
A3P-SENS-E-OXY	Sensor Module ISO-OXY Eng. Alert-3
A3P-SENS-E-VAC	Sensor Module ISO-VAC Eng. Alert-3
A3P-SENS-E-IAR	Sensor Module ISO-IAR Eng. Alert-3
A3P-SENS-U-AIR	Sensor Module USA-AIR Eng. Alert-3
A3P-SENS-U-OXY	Sensor Module USA-OXY Eng. Alert-3
A3P-SENS-U-VAC	Sensor Module USA-VAC Eng. Alert-3
A3P-SENS-U-WAG	Sensor Module USA-WAG Eng. Alert-3
A3P-SENS-U-IAR	Sensor Module USA-IAR Eng. Alert-3

## DISS KITS

Model Number	Description
S-DIS-KIT-OXY	DISS Demand Check, Nut and Nipple - OXY
S-DIS-KIT-AIR	DISS Demand Check, Nut and Nipple- AIR
S-DIS-KIT-VAC	DISS Demand Check, Nut and Nipple- VAC
S-DIS-KIT-N2O	DISS Demand Check, Nut and Nipple - N2O
S-DIS-KIT-NIT	DISS Demand Check, Nut and Nipple - NIT
S-DIS-KIT-EVA	DISS Demand Check, Nut and Nipple - WAG/AGS
S-DIS-KIT-IAR	DISS Demand Check, Nut and Nipple - IAR
S-DIS-KIT-CO2	DISS Demand Check, Nut and Nipple - CO2

## ACCESSORIES/MISC.

Model Number	Description
A3-MAN-ALM-ENG	Alert-3 Alarm Manual English
A2P-POWER-V2	Power Supply Module
A2P-BOXASS-3LCD	Alarm Back Box Assembly 3-Station
A3P-FRMASS-E-LCD	Alert-3 Alarm Frame Assembly LCD-English (ISO)
A3P-FRMASS-U-LCD	Alert-3 Alarm Frame Assembly LCD-US (NFPA)
A2P-PIPE	Pressure Module Pipe Assembly
A3P-DEMO-CASE	Alert-3 Demo Alarm

# Spare Part Numbers

## DEMAND CHECK VALVES

Model Number	Description
S-DIS-DEMC-AIR	DISS Demand Check Valve 1/4" MNPT - AIR
S-DIS-DEMC-CO2	DISS Demand Check Valve 1/4" MNPT - CO2
S-DIS-DEMC-NIT	DISS Demand Check Valve 1/4" MNPT - NIT
S-DIS-DEMC-N2O	DISS Demand Check Valve 1/4" MNPT - N2O
S-DIS-DEMC-EVA	DISS Demand Check Valve 1/4" MNPT - WAGD/AGSS
S-DIS-DEMC-OXY	DISS Demand Check Valve 1/4" MNPT - OXY
S-DIS-DEMC-VAC	DISS Demand Check Valve 1/4" MNPT - VAC
S-DIS-DEMC-IAR	DISS Demand Check Valve 1/4" MNPT - IAR

## RETRO-FIT PARTS

Model Number	Description
A3P-POWER-V4	Alert-3 Power Supply Module - Ver.4
A3P-BOX-3-FILL	AL-3 Alarm Box Filler Frame 3-Station - White Colour
A3P-BOX-4-FILL	AL-3 Alarm Box Filler Frame 4-Station - White Colour
A3P-BOX-4-FILL-3DP	AL-2/3 Conv Alarm 3" Deep Filler Frame - White Colour
A3P-BOX-5-FILL	AL-3 Alarm Box Filler Frame 5-Station - White Colour
A3P-BOX-7-FILL	AL-3 Alarm Box Filler Frame 7-Station - White Colour
A3P-CONKIT-GANG-3	For 3 Gang Conv Trim Plate - White Colour
A3P-CONKIT-GANG-4	For 4 Gang Conv Trim Plate - White Colour
A3P-CONKIT-GANG-5	For 5 Gang Conv Trim Plate - White Colour
A3P-CONKIT-GANG-7	For 7 Gang Conv Trim Plate - White Colour
A2P-CON-FTUBE	AL-2/3 Conv Sensor Flexible Tubing
A2P-CONKIT-CHEAN-1	Conv For 1 Gas Chem/Ncg Ana Medstar/Oxeq
A2P-CONKIT-CHEDI-1	Conv For 1 Gas Chem/Ncg/Allied Digital
A2P-CONKIT-MEDINT-1	Conv 1 Gas Medase/OHM/Medplus/Alert-1
A2P-CONKIT-OHI-1	Conv For 1 Gas Ohio/OHM Beige Digi/Ana
A2P-CONKIT-PBSER-1	Conv For 1 Gas Puritan Benet Series
A2P-CONKIT-SQUCOG-1	Conv For 1 Gas Squire Cogswell/ Product
A2P-CONKIT-TRITEC-1	Conv 1 Gas Tri-Tech/Beconmedes/PB Mega
A3P-LCD-FILLER-4	Alert-3 Filler Frame 4 - Station - White Colour
A3P-LCD-FILLER-5	Alert-3 Filler Frame 5 - Station - White Colour
A3P-LCD-FILLER-7	Alert-3 Filler Frame 7 - Station - White Colour

# Dimensions

## LCD ALARM

Inch  
[mm]

Front View

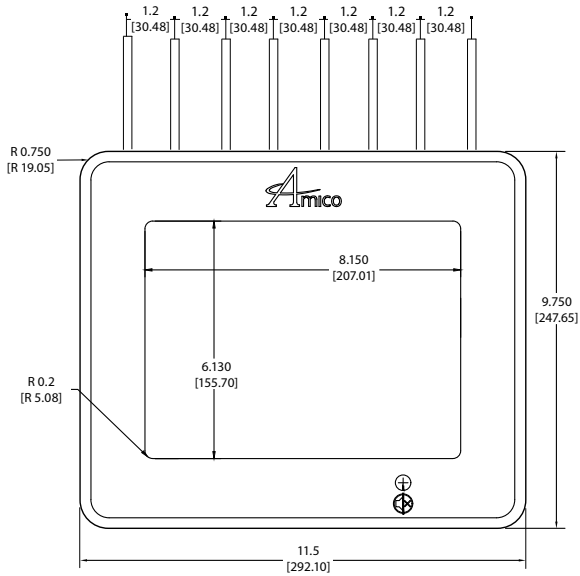

Side View

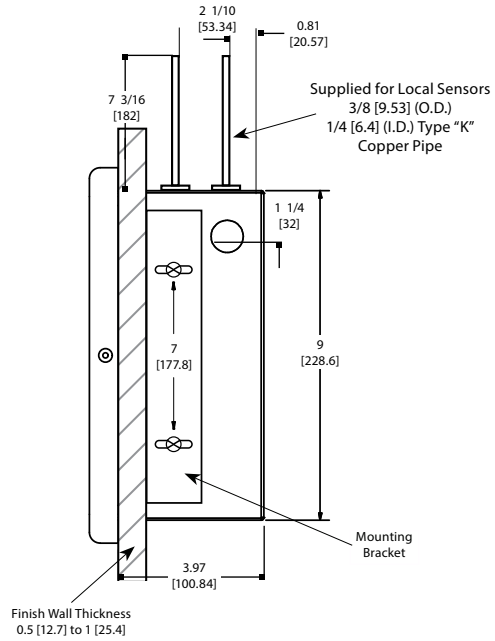

**NOTE:** DISS demand check valves by 1/4 [6] NPT, supplied with each sensor

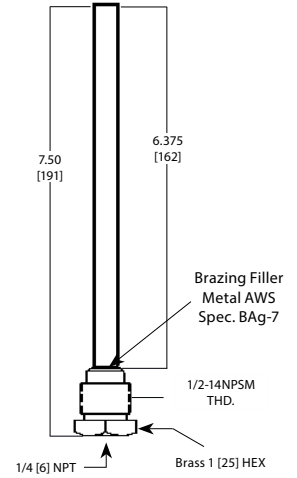

Top View

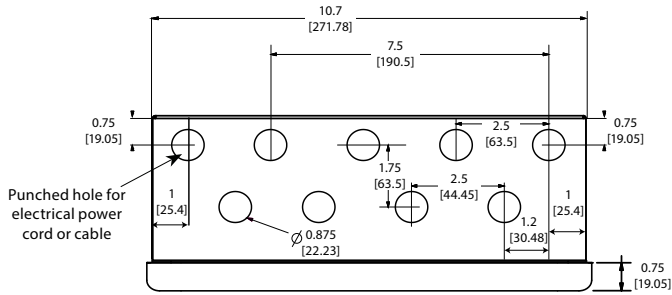

Bottom View

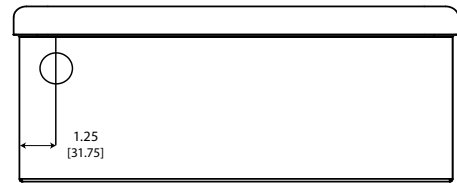

**NOTE:** LCD Alarm itself is 8 lbs. Each sensor is 1 lb.

## ALERT-3 SENSOR

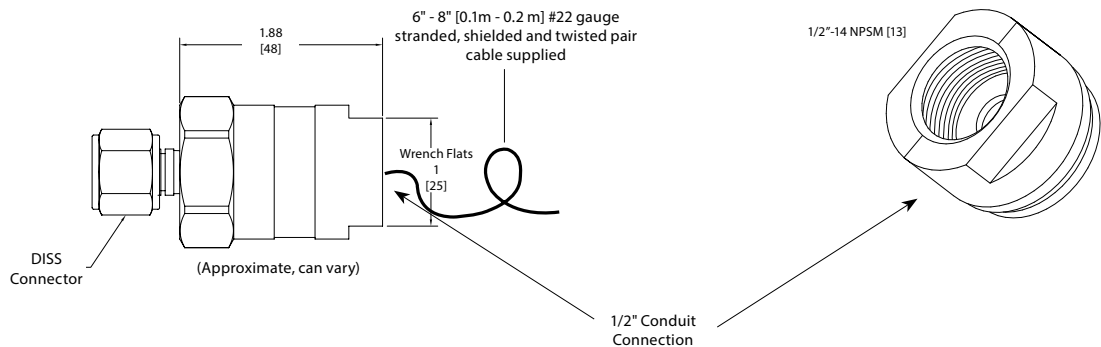

# Troubleshooting

Symptom	Cause	Corrective Action
An error or "LOW ALARM" LCD screen	The Microprocessor detected a fault and has shut down	Switch power switch to OFF position. Wait for at least 5 seconds before switching ON the power. The program will reset itself.
	Faulty wire connection between the sensor and LCD module	Check wiring diagram in Appendix D and Appendix E.
No power on the alarm	AC power not available	<ul style="list-style-type: none"> <li>a. Ensure that the ON/OFF switch on the power supply module is switched ON (see Appendix B).</li> <li>b. AC wiring not connected.</li> <li>c. Check the building electrical breaker to ensure that the power is ON.</li> <li>d. Check the voltage at the terminal block above the transformer. Ensure that 115 VAC to 220 VAC is being supplied.</li> </ul>
	Fuse is blown	Check the fuse. The fuse is located on the upper-right corner of the system power supply. Replace the fuse if it is defective (see Appendix B and Appendix G).
	DC power plug not connected to the LCD module	<ul style="list-style-type: none"> <li>a. Ensure that the DC power plug is firmly in its socket on the LCD alarm.</li> <li>b. Replace the System Power Supply unit if all the above steps fail to resolve the problem.</li> </ul>
Power light is ON, however there is no display on LCD screen	Power failure on screen	<ul style="list-style-type: none"> <li>a. Remove all transducers and reset power by switching the power supply OFF then ON.</li> <li>b. Check the DC power voltage. If DC power drops or changes, replace the power supply (Appendix B).</li> <li>c. Replace the LCD alarm.</li> </ul>
No audible alarm	DC power cable is disconnected or loose connection	<ul style="list-style-type: none"> <li>a. Ensure that the DC power cable from the system power supply is firmly connected to the LCD alarm.</li> <li>b. Check the volume control (see page 11, step 9 - ii).</li> <li>c. Replace LCD frame assembly.</li> </ul>
Audible signal will not silence	Faulty display module	Disconnect the back of the faulty display module and replace the LCD frame assembly.
	Connection of the DC power cable from system power supply to LCD alarm is loose	Disconnect the DC power cable from the LCD module and then reconnect. If audible alarm still persists, replace the LCD frame assembly.
	Faulty push button (broken)	Replace the LCD frame assembly.

# Troubleshooting

Symptom	Cause	Corrective Action
Gas reading incorrect	Loose connection of DISS fittings	Ensure that the sensor module is properly connected to the DISS demand check-valve.
	Sensor module is not properly wired to the display module	Ensure that the sensor module is properly wired to the LCD alarm by using wiring diagram in Appendix D or Appendix E.
	Requires calibration	Re-calibrate pressure reading (see pg. 11, step 9 - iv, "CURRENT OFF SET").
	Defective sensor	<p>a. Disconnect the sensor and make sure there is no moisture or water. It is recommended to check the filter.</p> <p>b. Replace the sensor module.</p>
	Defective LCD display	Replace the LCD alarm.
Display shows "NO SENSORS" or "MISSING"	No sensor(s) are connected to the LCD alarm	Make sure sensor module(s) are connected to LCD alarm (see Appendix D and Appendix E).
	Program not set up	Press setup and select button to program all connected sensors (see pg. 11, step 9).
	Faulty sensors	Replace sensors.

## FACTORY DEFAULT SETTING GAS

Mid Pressure    Hi       =     60 psi  
                          Low      =     40 psi

Vacuum         Hi       =     32 inHg  
                          Low      =     12 inHg

High Pressure    Hi       =     195 psi  
                          Low      =     140 psi

# Appendix A

## WIRING DIAGRAM: LCD BOARD

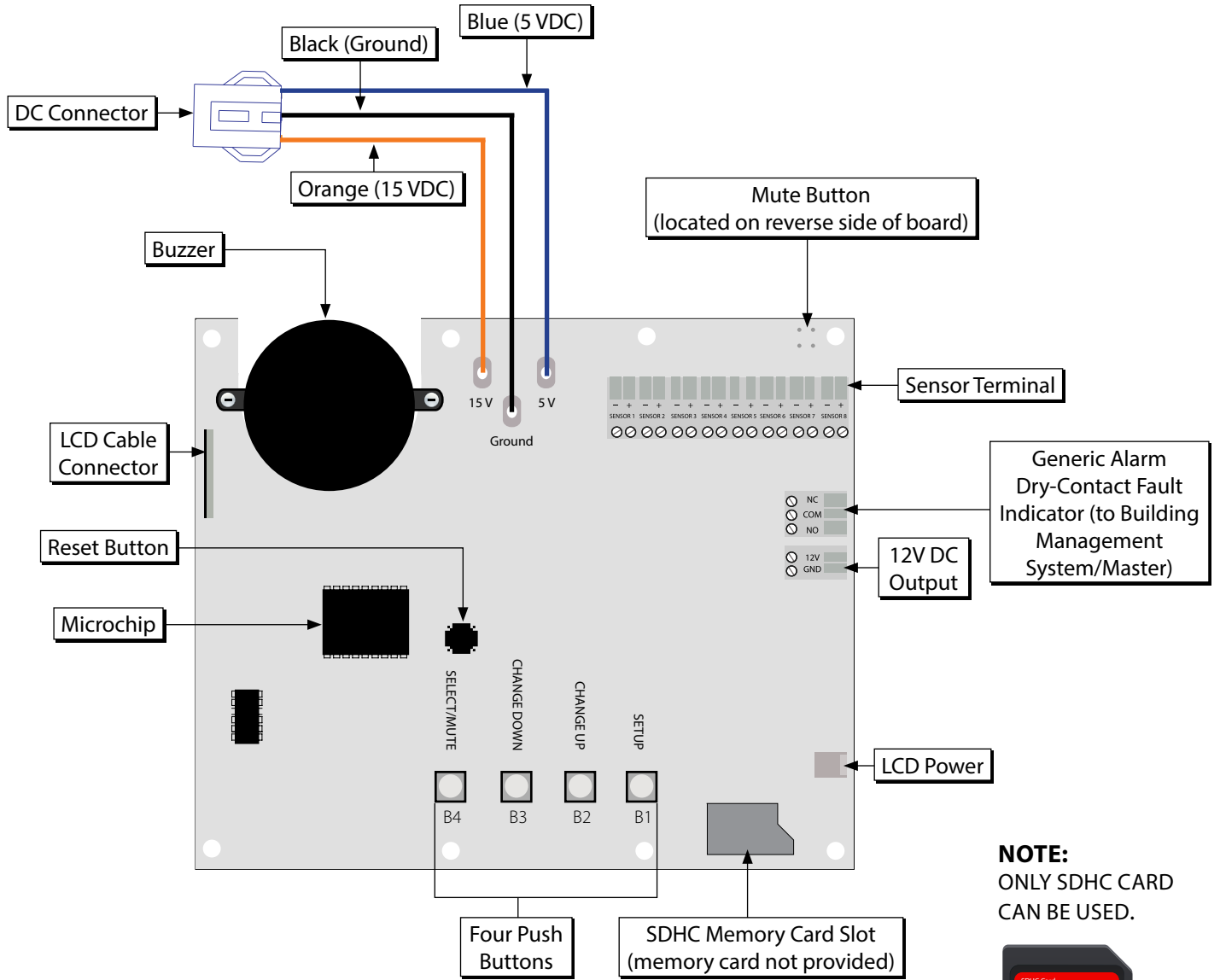

**NOTE:**  
ONLY SDHC CARD  
CAN BE USED.

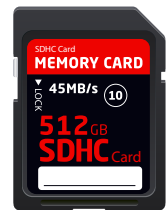

### CAUTION:

1. Keep the shield drain wires as short as possible and taped to prevent from grounding, so they cannot touch the front panel circuit board when front panel is closed.
2. To protect from static electricity, ensure to discharge body static before installing the Medical Gas Alarm and Sensors.
3. Warranty void if push button is broken or if the frame assembly is disassembled.

# Appendix B

## WIRING DIAGRAM: AUTO-SWITCH POWER SUPPLY

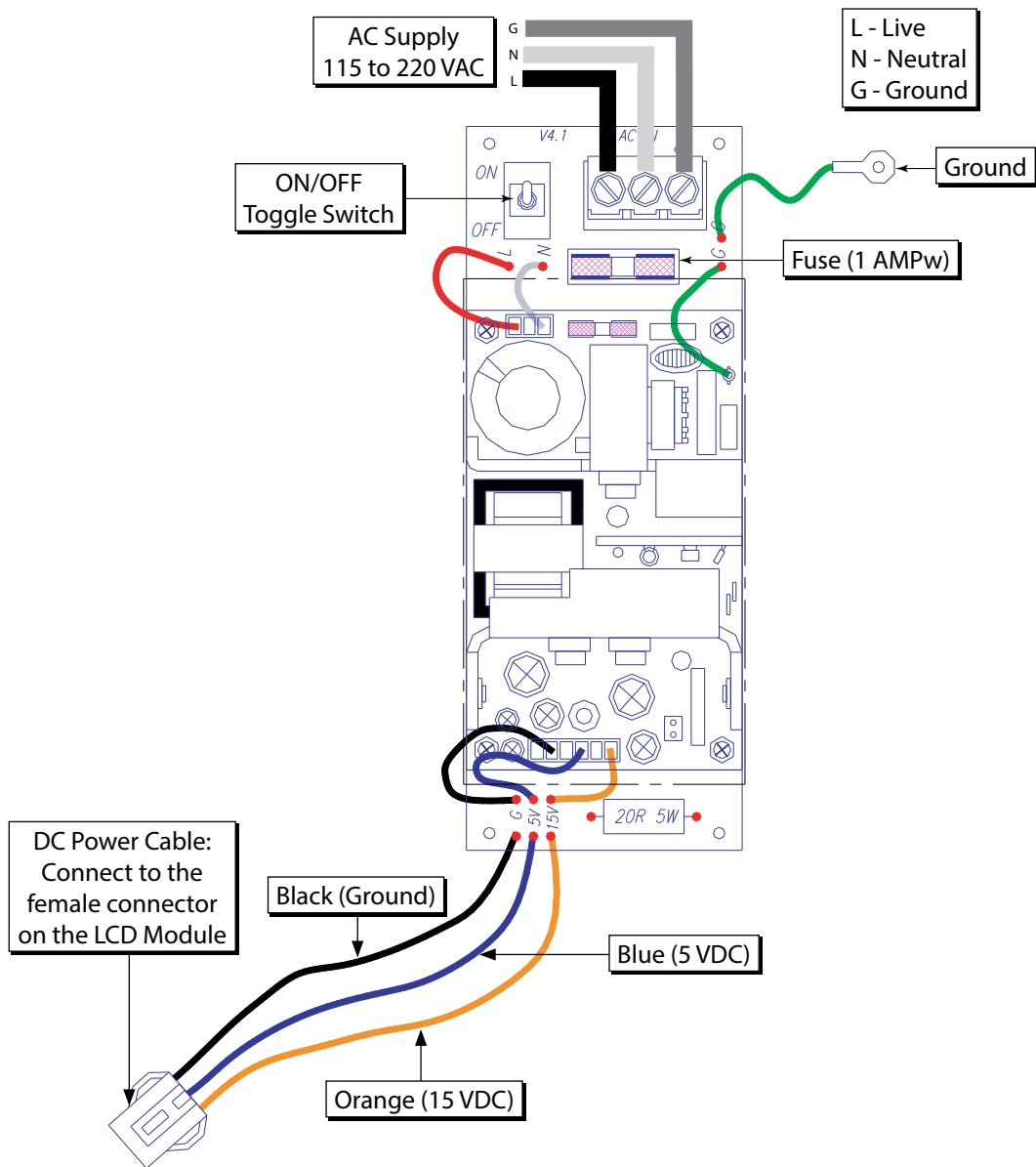

### CAUTION:

1. Verify that power has been switched off prior to working on the alarm
2. Risk of electric shock, disconnect power at the circuit breaker before removing power supply shield

# Appendix C

## WIRING DIAGRAM: LCD DISPLAY BOARD - ALARM BUZZER

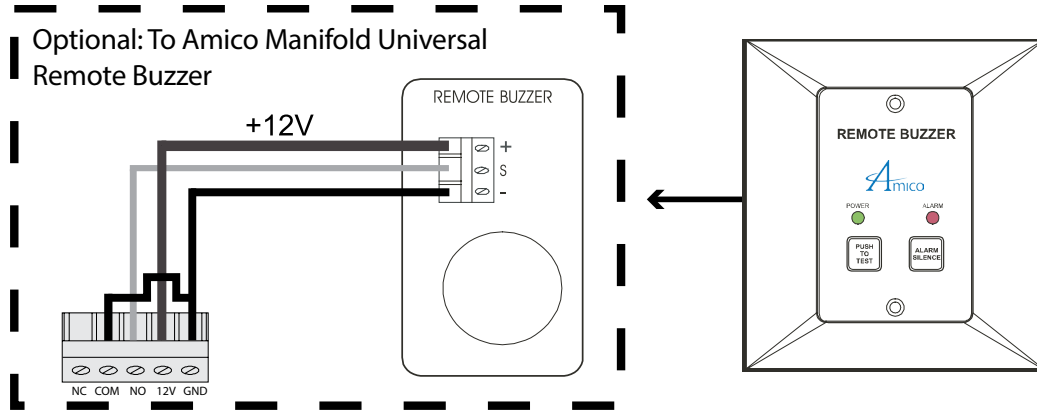

**NOTE:** AMICO RECOMMENDS MAX. 50 FT. TO POWER UP BUZZER FROM ALARM PANEL TO POWER UP THE BUZZER. MORE THAN 50 FT., A A3P-POWER-V4 IS REQUIRED TO SUPPLY VOLTAGE FOR THE ALARM BUZZER.

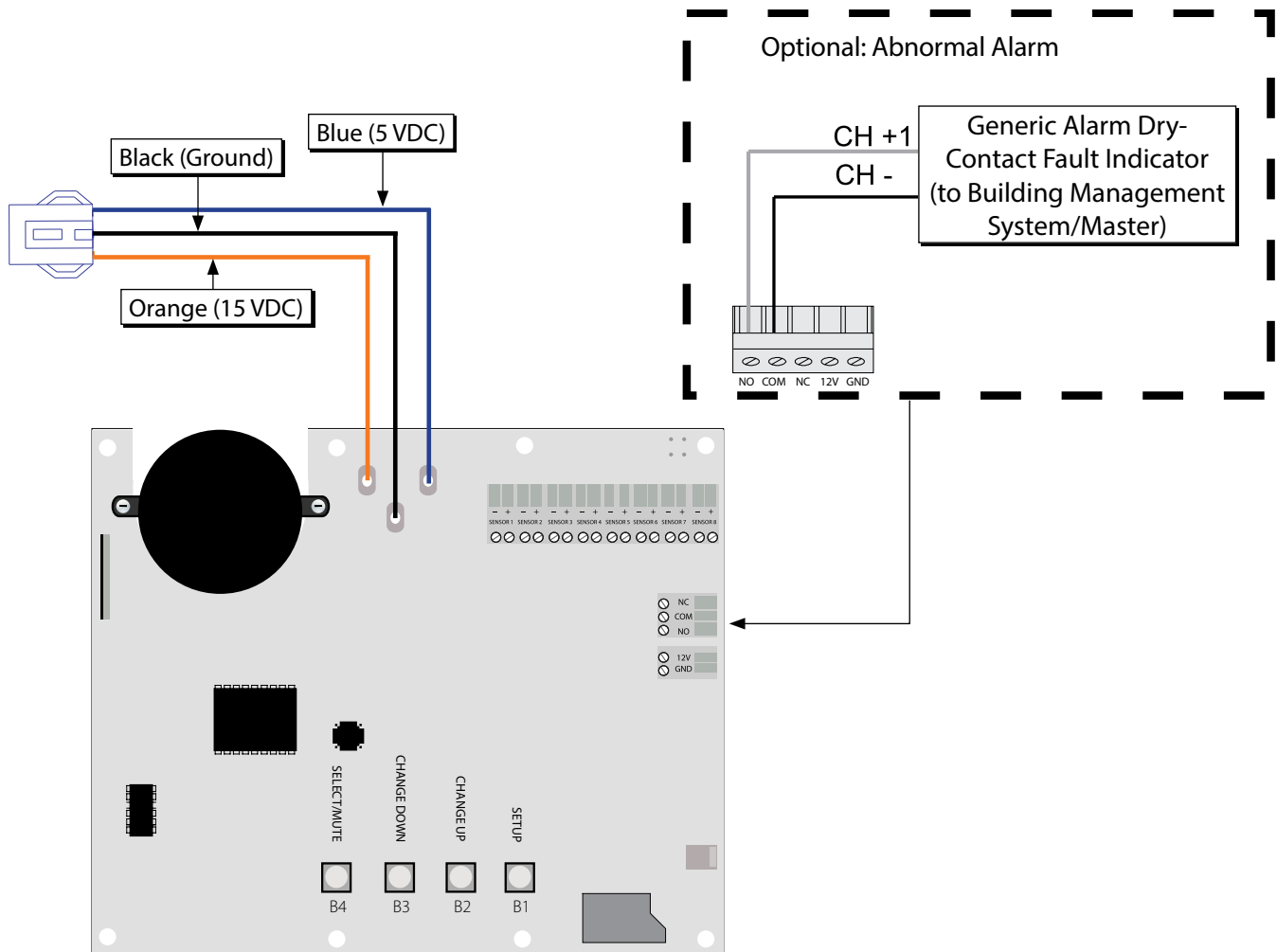



# Appendix D

## WIRING DIAGRAM: LCD DISPLAY BOARD - LOCAL SENSOR

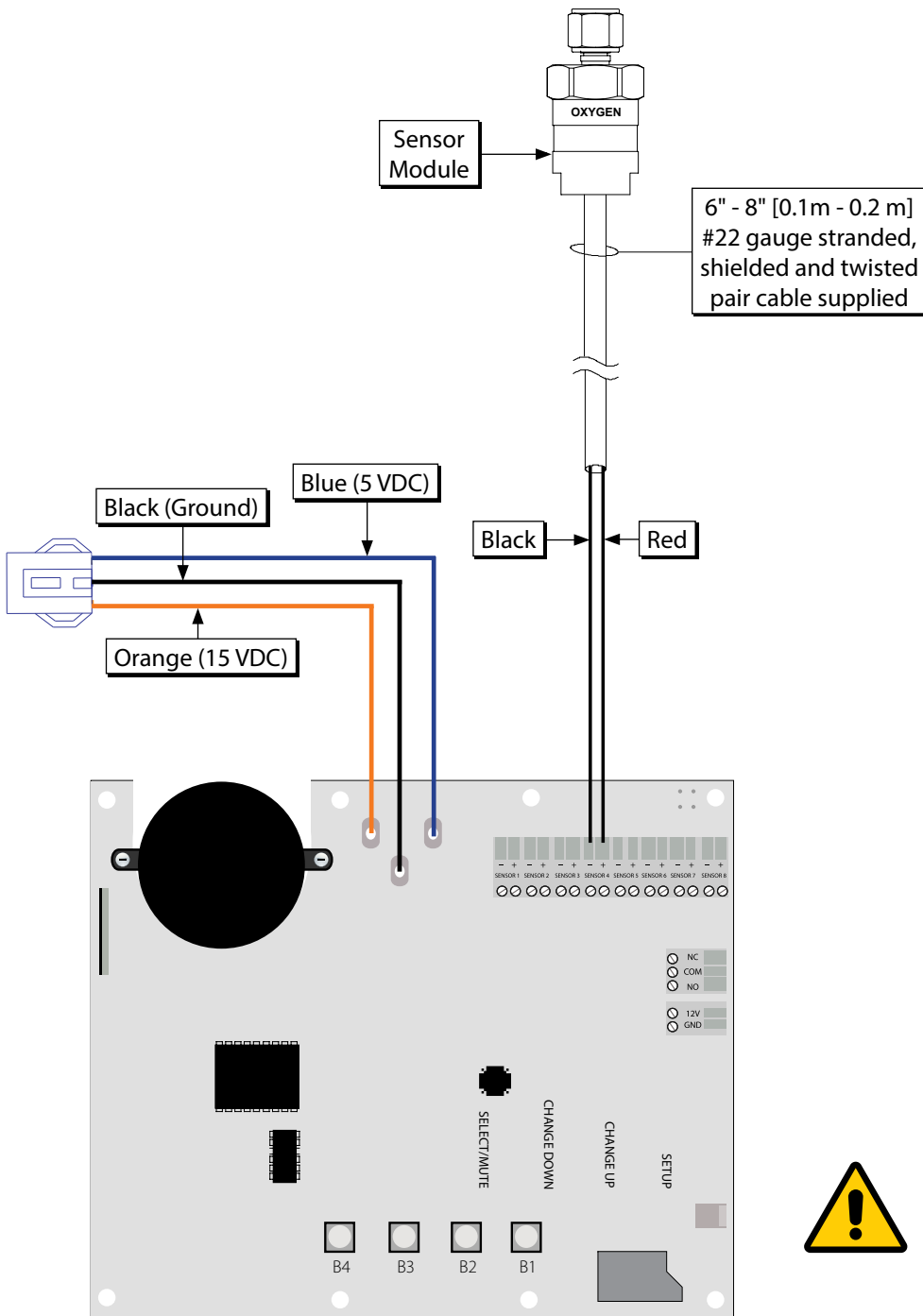

### NOTE:

Do not ground the shield drain wire at sensor or inside alarm panel back box



### CAUTION:

To protect from static electricity, ensure to discharge body static before installing the Medical Gas Alarm and sensors

# Appendix E

## WIRING DIAGRAM: LCD DISPLAY BOARD - REMOTE SENSOR

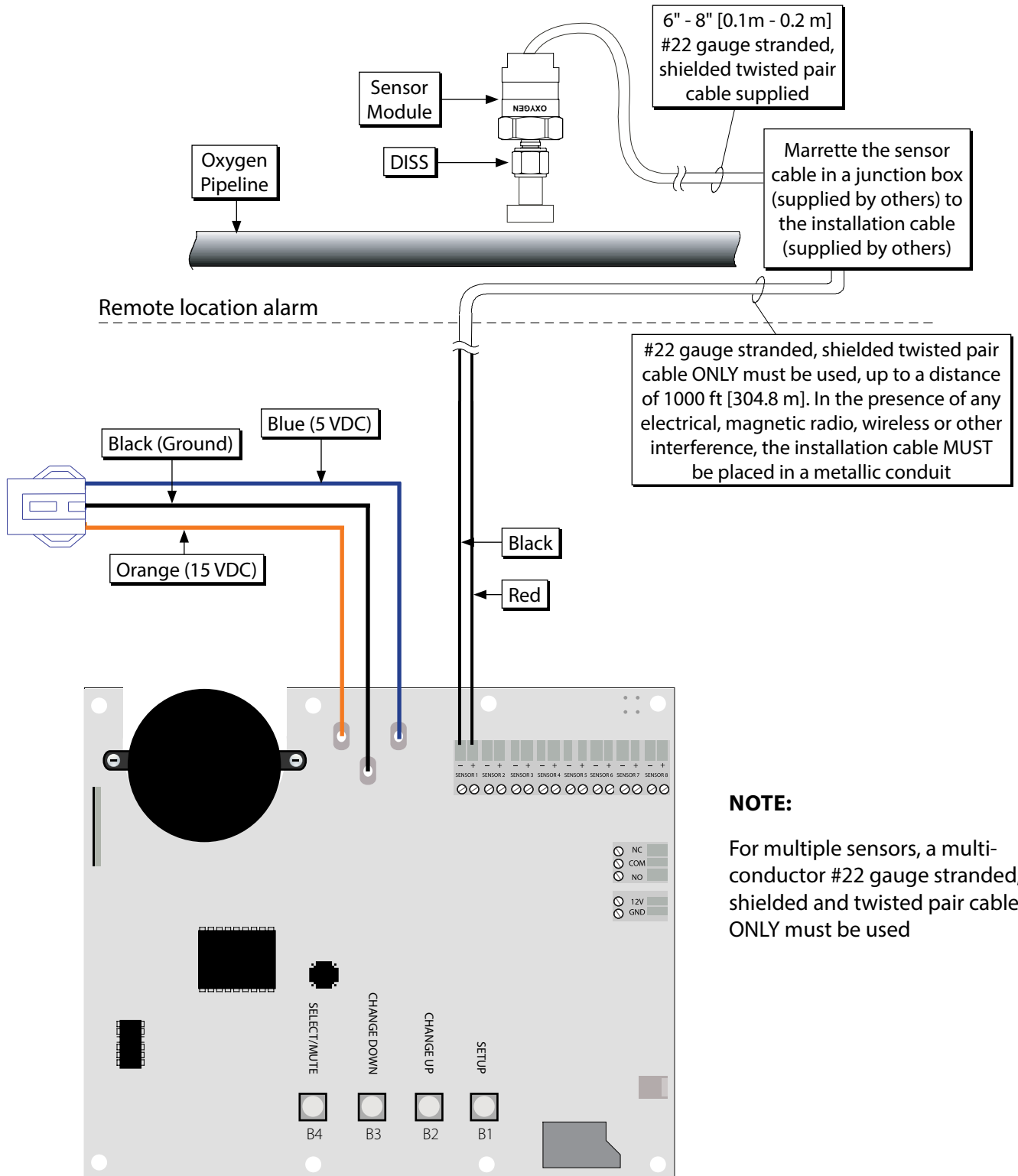

# Appendix F

## WIRING DIAGRAM: LCD DISPLAY BOARD - MASTER MODULE

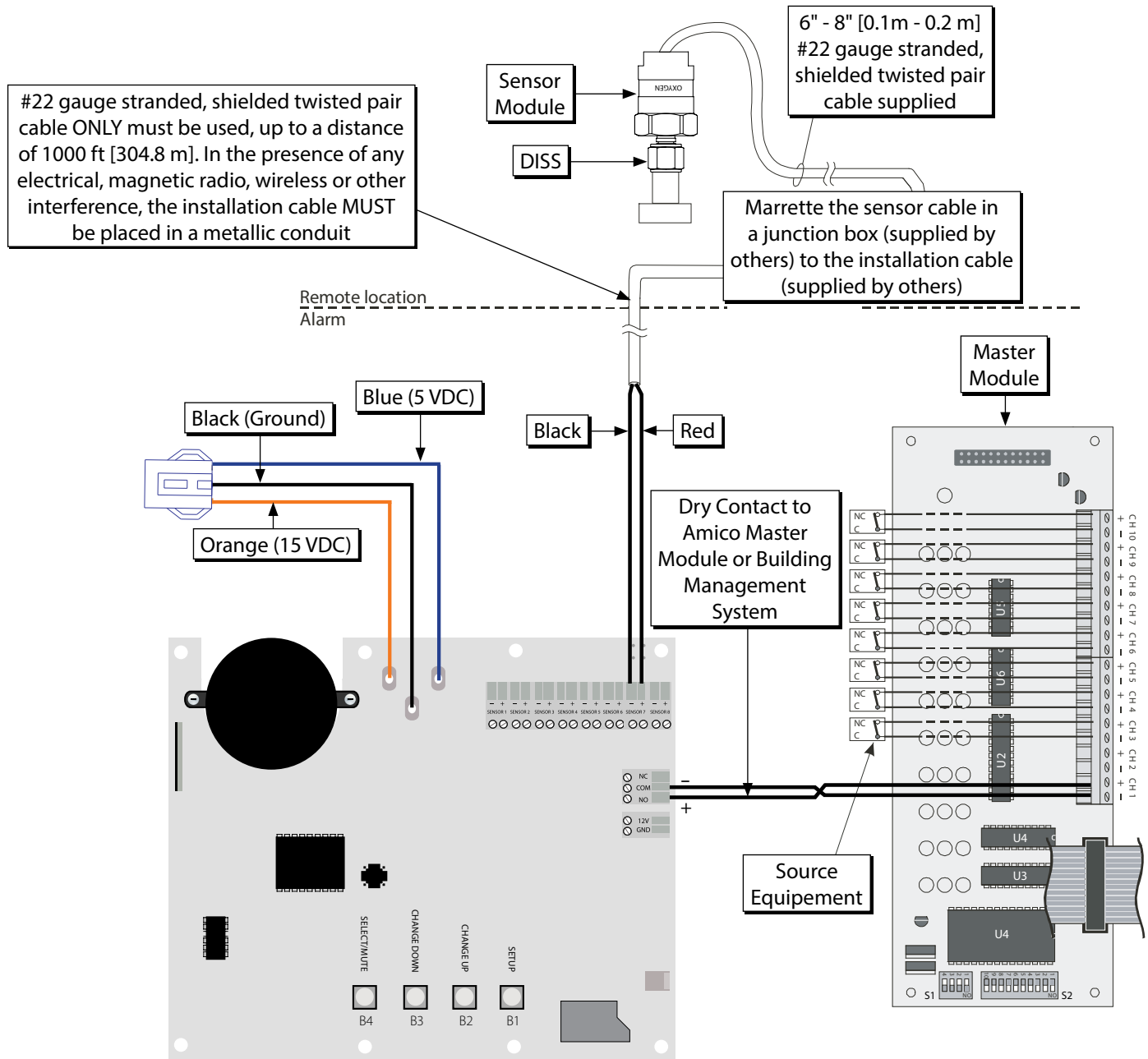

### NOTE:

Jumper any unused points on the Master module. Turn OFF dip-switches for any unused points (Location SW-2)



### CAUTION:

For Master Alarm, source equipment signal wires must be connected to normally-closed dry contacts. No electrical voltage can be present and contacts must be closed during normal equipment operation. When contacts are open; an alarm condition will be activated.

# Appendix G

## TECHNICAL SPECIFICATIONS

Supply Voltage: 115 - 220 VAC, 50 - 60 Hz  
Current Draw: 1 Amp. Max.  
Fuse (1/4 \* 1-1/4): Fast Blow 1 Amp.

Cable requirement:

LCD Alarm to Remote Sensor:

**Important:**

**Cable: ONLY a #22 gauge stranded, shielded twisted pair cable must be used. (Belden # 8451 or equivalent.) In the presence of any electrical, magnetic, radio frequencies, wireless or other interference, cable installation MUST be placed in metallic conduit.**

Distance: Maximum 1000 ft [304.8 m]  
Signal: 30 VDC - 1.0 Amps.  
60 VDC - 0.3 Amps.  
125 VAC - 0.5 Amps.

LCD Alarm to Master:

Distance: Maximum 10,000 ft [3,000 m]  
Cable: Minimum #22 gauge stranded wire (does not have to be shielded, twisted pair)  
Signal: 5 VDC - < 5  $\mu$ A

LCD Generic Alarm:

Output: Dry Contacts NC, open on Alarm  
Rating: 30 VDC - 1.0 Amps.  
60 VDC - 0.3 Amps.  
125 VAC - 0.5 Amps.

### NOTE:

For Master Alarm, source equipment signal wires must be connected to normally-closed dry contacts. No electrical voltage can be present and contacts must be closed during normal equipment operation. When contacts are open; an alarm condition will be activated.

# Appendix H

## WIRING

### 1. General Requirements

1. All wiring shall be protected from physical damage by raceways, cable trays or conduit in accordance with NFPA 70, National Electric Code or the Canadian Electrical Code.
2. All alarms are to be powered from the life safety branch of the emergency power system as required by applicable standards.
3. Alarm panel wires should be directly connected to switches or sensor as required by applicable standards.
4. All wire runs should be made with color coded wire. Record color, signal and source of signal for each wire lead to aid in connection of alarm finish components.
5. The alarm panel and remote sensors should not be installed near radio transmitters, electrical motors, electrical control room, switchgear, CT scanners, MRI machines or high voltage lines
6. In the presence of any electrical, magnetic, radio frequencies, wireless or other interference, cable installation MUST be placed in metallic conduits.
7. No solid wire should be used for connecting sensors or master alarms to source equipment
8. To protect from static electricity, ensure to discharge body static before installing the Medical Gas Alarm and Sensors
9. Do not ground the shield drain wire at sensor or inside alarm panel back box
10. Electrical cable should not run below sensors or behind the alarm box, to protect from radio frequencies and EMI

### 2. Low Voltage wire type, size and other requirements

All low voltage wiring must meet the following criteria:

1. #22 AWG stranded, shielded twisted pair wire ONLY must be used, rated for 300V and 60°C (140°F) minimum. (Belden 8451 or equivalent)
2. Marrette the sensor cable in a junction box (supplied by others) to the installation cable (supplied by others) to protect from physical damage, radio frequencies and EMI
3. For multiple sensors, a multi-conductor #22 gauge stranded, shielded and twisted pair cable ONLY must be used

The following rules along with references to this manual's schematics clarify wiring requirements. Two conductor cables (must be #22 gauge stranded, shielded and twisted pair cable type) are required for each Gas Sensor module to the Gas Input board.



**954-725-1470 Ext. 403**