

Installation and Maintenance Manual

Medical Gas Outlets

DISS, Ohmeda, Chemetron, Puritan-Bennett
& Oxequip/MedStar Compatible



Puritan-Bennett
Compatible



Chemetron
Compatible



Ohmeda
Compatible



DISS



Oxequip/MedStar
Compatible



Contents

Product Description	3
Cleaning and Lubricating	4
Inspection and Testing	4
Test for Leaks	4
Test for Indexing	4
Installation & Dimensions	5-7
Wall Outlet	5
Ceiling Outlets - DISS	6
Console Outlet	6
Ceiling Column Outlet	7
Service	8
Latch Valve Assembly - DISS	8
Latch Valve Assembly - Ohmeda Compatible	9
Latch Valve Assembly - Chemetron Compatible	10
Latch Valve Assembly - Puritan-Bennett Compatible	11
Latch Valve Assembly - Oxequip/MedStar Compatible	12
Rough-in Assembly - Wall and Console	13
Model Numbers	14-15
Complete Assembly	14
Latch Assembly	14
Rough-in Assembly	15
Gas Indexing	16
Replacement Components	17-22
Latch Valve Assembly - Ohmeda Compatible	17
Latch Valve Assembly - Chemetron Compatible	18
Latch Valve Assembly - DISS	19
Latch Valve Assembly - Puritan-Bennett Compatible	20
Latch Valve Assembly - Oxequip/MedStar Compatible	21
Rough-in Assembly - Wall and Console	22

Product Description

The Amico Medical Gas outlet is composed of two separate modules: the “Rough-in Assembly” and the “Latch Valve Assembly”. The “Rough-in Assembly” is the same for all types (DISS, Ohmeda, Chemetron, Puritan-Bennett or Oxequip/MedStar), while the “Latch-valve assembly” determines what type of adapter the outlet will accept.

The “Rough-in Assembly” consists of a brass machined body that incorporates a spring loaded check assembly. A 1/2" [12.7 mm] OD copper pipe is silver brazed into the body for external pipeline connections. The brass body and pipe assembly are inserted into a gas specific plate. The wall outlets can be ganged together at 5" [127 mm] centers (see page 5). This makes for a finished assembly that looks like one complete panel of outlets. The “Rough-in Assembly” has a color coded label on the copper pipe, so that the installer can easily identify the gas that the copper pipe should be connected to. The “Rough-in Assembly” incorporates a check valve that allows the “Latch Valve Assembly” to be removed for service, without requiring the pipeline to be shut down. The “Rough-in Assembly” has a DUAL pin gas specific indexing arrangement to prevent the wrong “Latch Valve Assembly” from being plugged into the “Rough-in Assembly” (see page 17).

The “Latch Valve Assembly” is manufactured in five different models: DISS, Quick connect Ohmeda compatible, Quick connect Chemetron compatible, Quick connect Puritan-Bennett compatible or Quick connect Oxequip/MedStar compatible. The DISS “Latch Valve Assembly” is permanently riveted together, so that the gas specific components cannot be taken apart, to ensure they remain gas specific. All the servicing on the DISS outlet is done inside the connector. On the Quick connect models the connector plate can be removed for additional O-Ring servicing, but is still gas specific since the gas specific parts are permanently riveted together. The “Latch Valve Assembly” consists of: a connector with an integral check valve, an indexing block complete with indexing pins, a color coded gas front plate and a chrome frame. The “Latch Valve Assembly” is inserted into the “Rough-in Assembly” and secured screws.



CAUTION: DO NOT overtighten the Latch Valve Mounting screws! Distortion of the Latch Valve can occur.

The quick connect models are compatible with the Ohmeda Diamond, the Oxequip/MedStar, the Chemetron, and the Puritan-Bennett quick connect adapters. Only the corresponding type of adapters can be used with the quick connect outlets. The DISS outlet conforms to the CGA Pamphlet V-5 standards. Since the “Rough-in Assembly” is the same for all models of “Latch Valve Assembly”, the outlet can easily be converted from one type to another by simply replacing the “Latch Valve Assembly”.

NOTE:

For ceiling applications, only DISS Outlets are recommended.

This device has been manufactured to conform to the standards, specifications and operating procedures stated in this manual when installed, inspected, operated, maintained, and serviced in accordance with these instructions.

The user of the device shall have the sole responsibility for any malfunction which results from improper installation, use, maintenance, alteration, or modification.



WARNING: Keep all components dry and clean during installation. DO NOT alter or modify this device or any of its components in any way. Store in normal working and environmental conditions. Adverse environmental conditions, harsh abrasives or chemicals will cause damage to the unit.

Cleaning and Lubricating

The Amico Outlets are factory cleaned for Oxygen service. Exposed surfaces of the outlet may be cleaned with a mild detergent solution or wiped with a disinfectant commonly used in patient rooms, that is compatible with plastics, anodized aluminium and die cast zinc. Lubricate elastomer seals sparingly with a silicone lubricant that is Oxygen compatible. **DO NOT USE OIL.**

Inspection and Testing

Medical Gas Outlets should be inspected periodically or at least once a year. The test should be in accordance with NFPA 99 "Gas and Vacuum systems" and or ISO 9170 "Terminal Units for Medical Gas Pipeline Systems".

Test for Leaks

Ensure that no leaks exists, with or without the adapter inserted.

Test for Indexing

Only a mating gas specific adapter should insert smoothly into the outlet, latch and be retained.

Refer to the appropriate standards for the proper way of performing the flow test.

NOTE:

The Amico Medical Gas and Vacuum Outlets meet and exceed these requirements at the time of manufacture. However piping source capacity, sizing, and restrictions may prevent outlets from attaining these values.



CAUTION: DO NOT braze rough-ins with front latch installed. Must use wet rag when brazing since the heat could damage the secondary check valve, seal and other installed components. Use only mild soap-based solution for leak testing.

Installation and Dimensions

Wall Outlets

DISS, Ohmeda, Chemetron, Puritan-Bennett, and Oxequip/MedStar compatible.

Inch
[mm]

When wall outlets are ganged together, ensure that they are 5" (127 mm) from center to center. DO NOT let the notches on the mounting plate pass the adjacent holes on the next mounting plate.

Do not bury the outlet during the drywall and plaster application. Ensure that the cover over the outlet is in place until the "Latch Valve Assembly" can be installed.

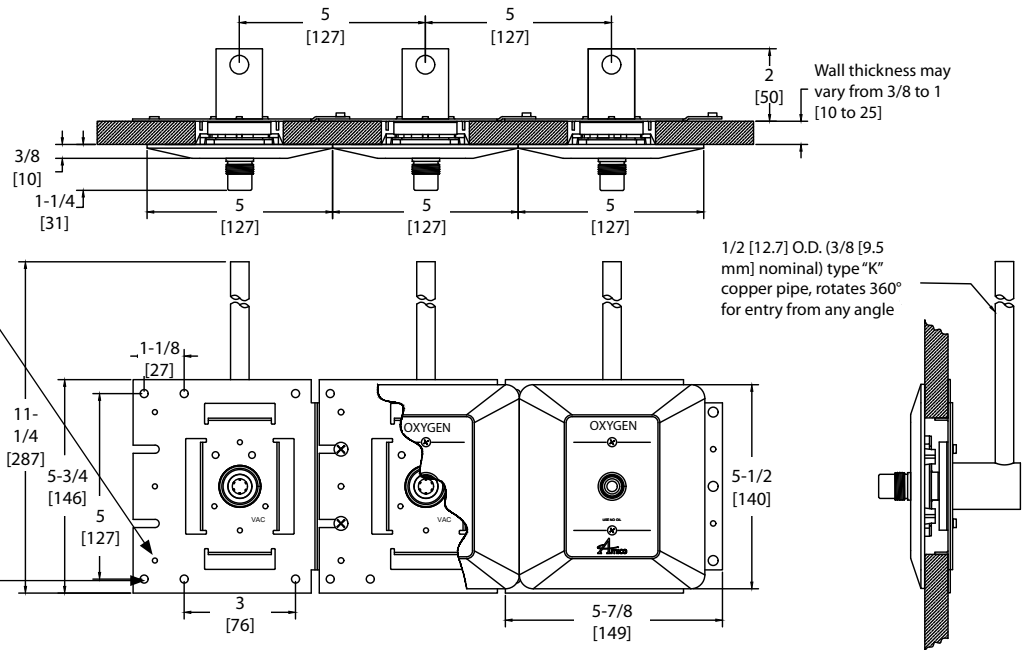

NOTE: Amico recommends that you have a blank space between outlets and slides. Maximum 3 outlets may be ganged together without additional support.

Installation and Dimensions

Ceiling Outlets - DISS

DISS, Ohmeda, and Chemetron compatible.

When wall outlets are ganged together, ensure that they are 5" (127 mm) from center to center. DO NOT let the notches on the mounting plate pass the adjacent holes on the next mounting plate.

Do not bury the outlet during the drywall and plaster application. Ensure that the cover over the outlet is in place until the "Latch Valve Assembly" can be installed.

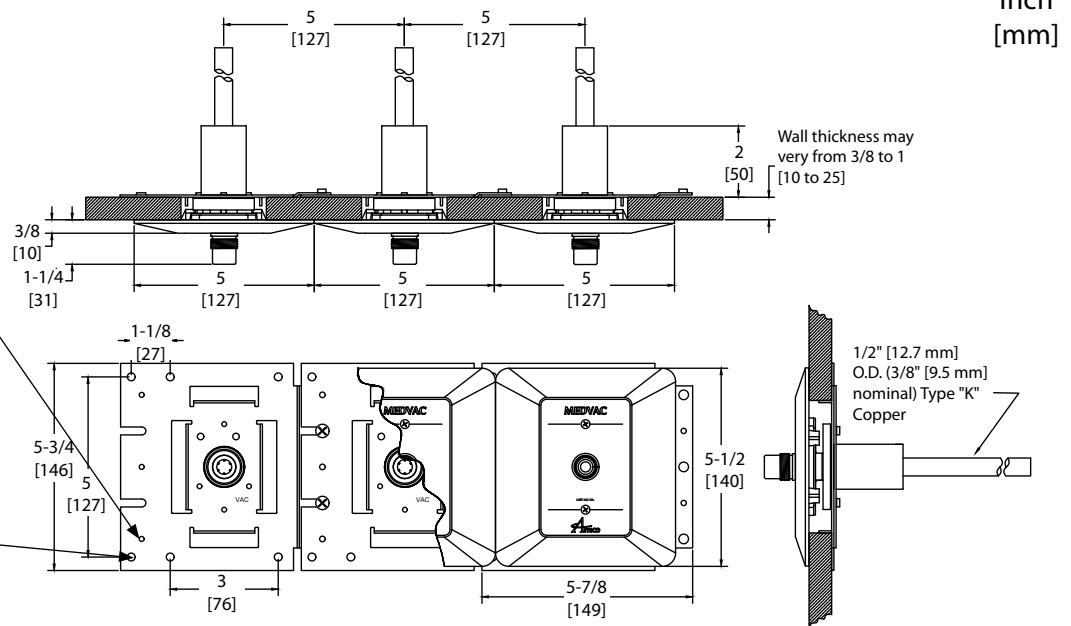

NOTE: Amico recommends that you have a blank space between outlets and slides. Maximum 3 outlets may be ganged together without additional support.

Console Outlets

DISS, Ohmeda, Chemetron, Puritan-Bennett, and Oxequip/MedStar compatible.

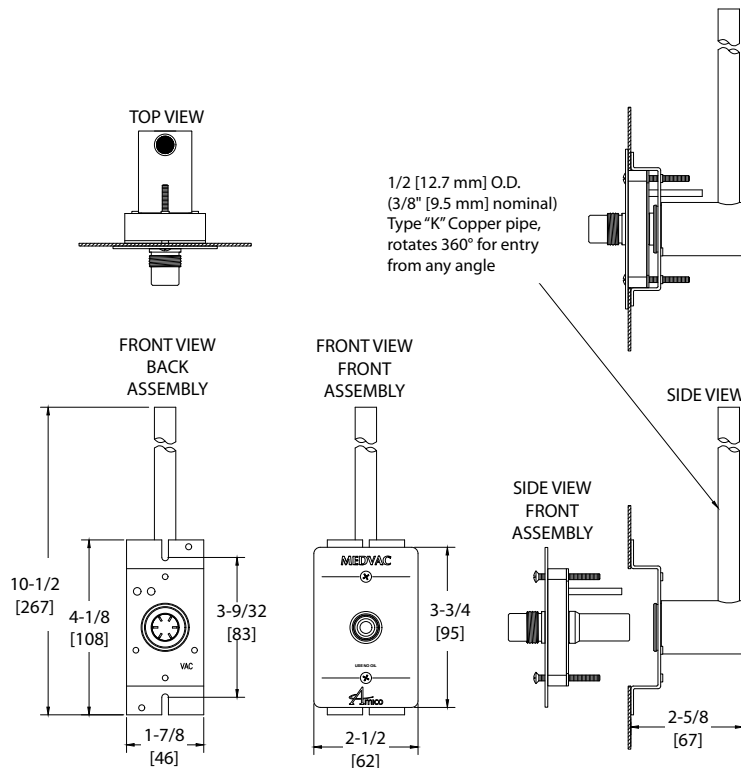

Installation and Dimensions

Ceiling Column Outlets

DISS, Ohmeda, Chemetron, Puritan-Bennett, and Oxequip/MedStar compatible.

Inch
[mm]

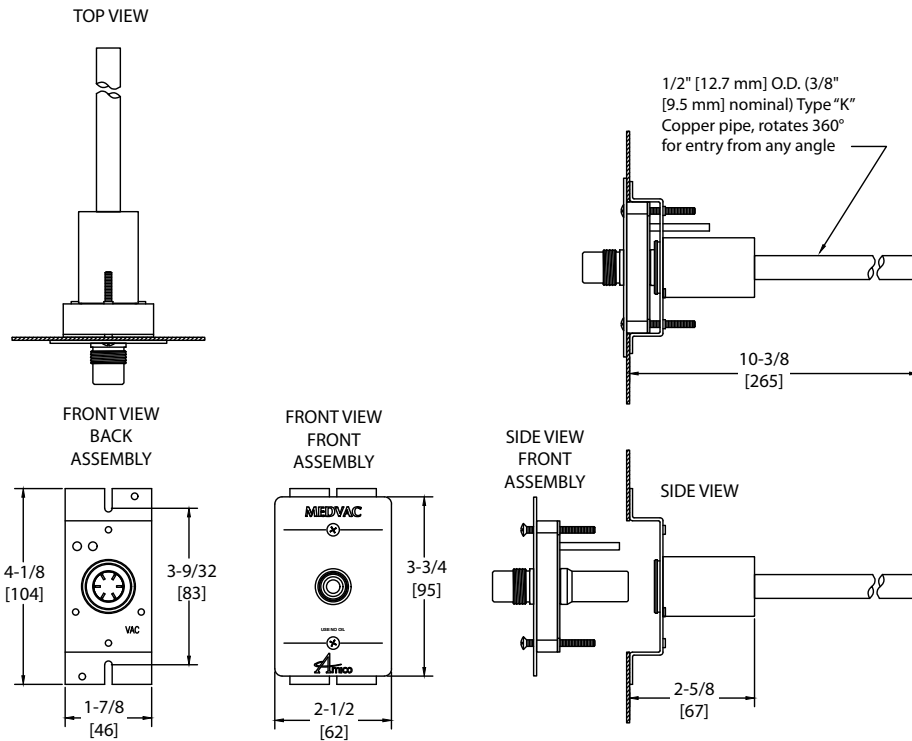

On all outlets (wall and console) the connecting pipe can swivel a full 360° for easy connection to the gas pipe.

When soldering the pipe connection take care not to heat up the body, since that could damage the secondary check valve.

It is very important to keep the protective cover/caps in place during construction, to ensure that no debris or dirt get into the outlet.

When installing the "Latch Valve Assembly", remove the protective cover and inspect for dirt or debris in the outlet body. Clean out the contaminants, if required.

The "Latch Valve Assembly" should slide in smoothly into the "Rough-in Assembly", if not, check that there is no damages to the indexing pin arrangements. If the indexing pins are bent or damaged, replace the "Latch Valve Assembly".

DO NOT PRESSURE TEST THE PIPELINE OVER 100 PSI [690 kPa] IF THE "LATCH VALVE ASSEMBLY" HAS BEEN INSTALLED.

All "Rough-in Assemblies" can be pressure tested up to a maximum of 200 PSI without the "Latch Valve Assembly" attached to it.

All "Latch Valve Assemblies" with the exception of Nitrogen DISS and Instrument Air have a Maximum pressure rating of 100 PSI [690 kPa].

The Nitrogen DISS and Instrument Air has a maximum pressure rating of 200 PSI [1,380 kPa].

After installation, perform the test on page 1.

Service

Before performing any maintenance on the Outlet, the appropriate hospital maintenance or engineering personnel should be notified. The "Latch Valve Assembly" can be removed without interrupting the service, but when servicing the "Rough-in Assembly" the supply pressure has to be shut off.

Latch Valve Assembly - DISS

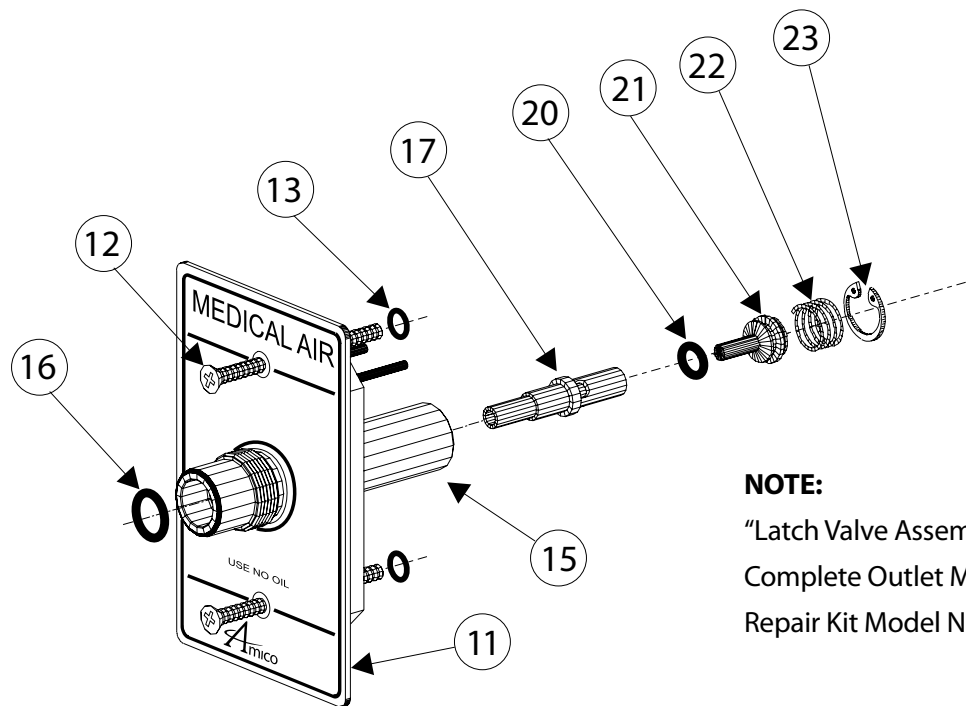

NOTE:

"Latch Valve Assembly" Model Numbers see Page 14
Complete Outlet Model Numbers see Page 14
Repair Kit Model Numbers see Page 19

1. Unscrew the two retaining screws (12) until the "Latch Valve Assembly" (11) can be removed from the outlet.
2. Remove the O-Ring seal (16) from the front and replace (NOTE: There is no O-Ring for Oxygen, Medical Air and Carbon Dioxide).
3. Remove the retaining ring (23) using appropriate pliers. Remove the valve stem (17), O-Ring seal (20), primary check valve (21) and spring (22). Inspect the items for wear or damage and replace if needed. Replace the O-Ring (20).
4. Re-install all internal components and lock in place with the retaining ring (23).
5. Re-install the "Latch Valve Assembly" into the outlet. Coat the connector (15) with a thin coat of Oxygen compatible silicone lubricant to aid insertion. Tighten down the retaining screws (12), DO NOT over tighten, as this could damage the Latch Valve.
6. Connect a gas specific adapter to the outlet. The connection should be smooth and hand tightening of the nut should be sufficient to allow the gas to flow without leakage. If not, replace the entire "Latch Valve Assembly" (11).

Latch Valve Assembly - Ohmeda Compatible

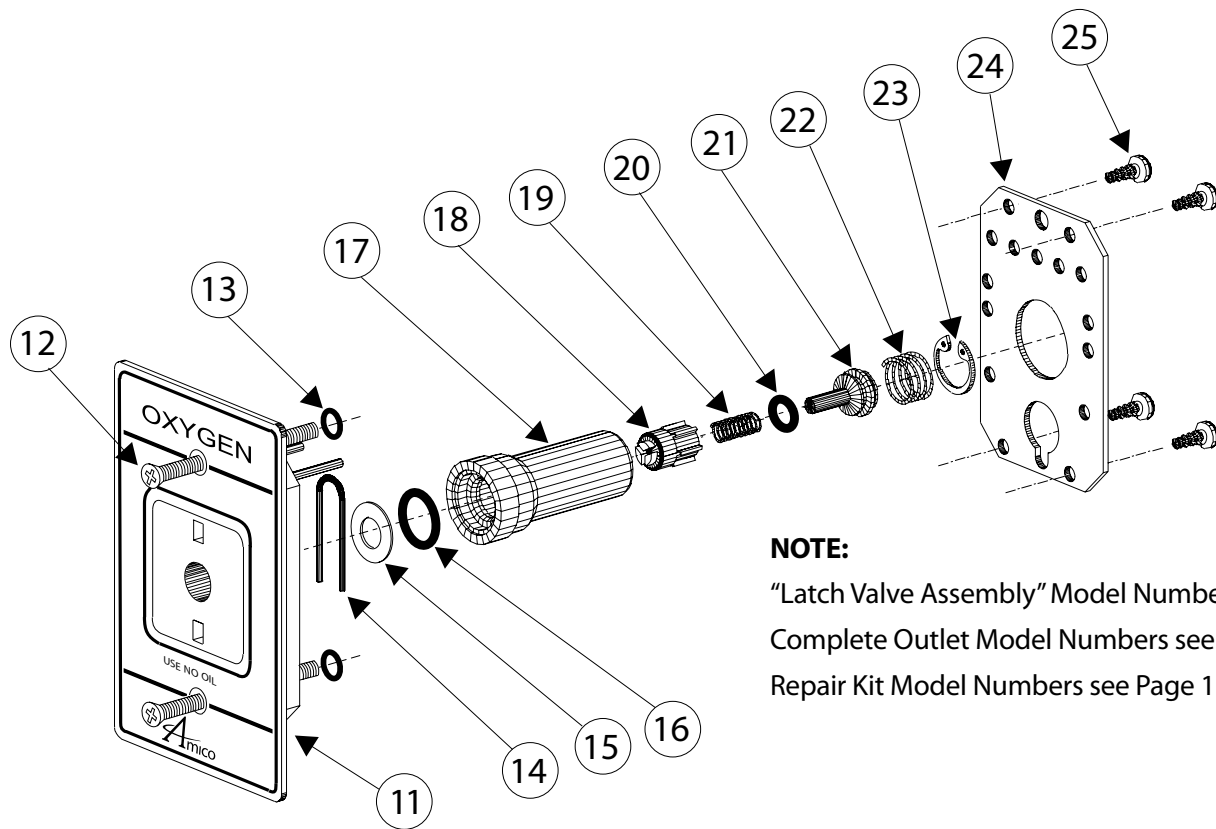

NOTE:

"Latch Valve Assembly" Model Numbers see Page 14

Complete Outlet Model Numbers see Page 14

Repair Kit Model Numbers see Page 17

1. Unscrew the two retaining screws (12) until the "Latch Valve Assembly" (11) can be removed from the outlet.
2. Remove the four screws (25) holding the connector retaining plate (24) in place. Remove the plate.
3. Remove the connector (17) from the Valve Assembly.
4. Remove the U-Spring (14), inspect for wear or damage, re-install the U-Spring.
5. Remove the flat washer (15) and connector O-Ring (16) from the front of the connector. Inspect the items for wear or damage and replace the O-Ring seal (16).
6. Remove the retaining ring (23) using appropriate pliers. Remove the dust cap (18), dust cap spring (19), O-Ring seal (20), primary check Valve (21) and spring (22). Inspect the items for wear or damage and replace if needed. Replace the O-Ring (20).
7. Re-install all internal components and lock in place with retaining ring (23). Insert the Connector (17) into the gas specific body. Check that the U-Spring (14), flat washer (15) and O-Ring (16) are in place. Re-install the connector retaining plate (24) and secure with four screws (25), do not overtighten.
8. Re-install the "Latch Valve Assembly" into the outlet. Coat the connector (17) with a thin coat of Oxygen compatible silicone lubricant to aid insertion. Tighten down the retaining screws (12), DO NOT over tighten, as this could damage the Latch Valve.
9. Connect a gas specific adapter into the outlet. The connection should be smooth and the adapter should lock and remain in place allowing gas to flow. If not replace the entire "Latch Valve Assembly" (11).

Latch Valve Assembly - Chemetron Compatible

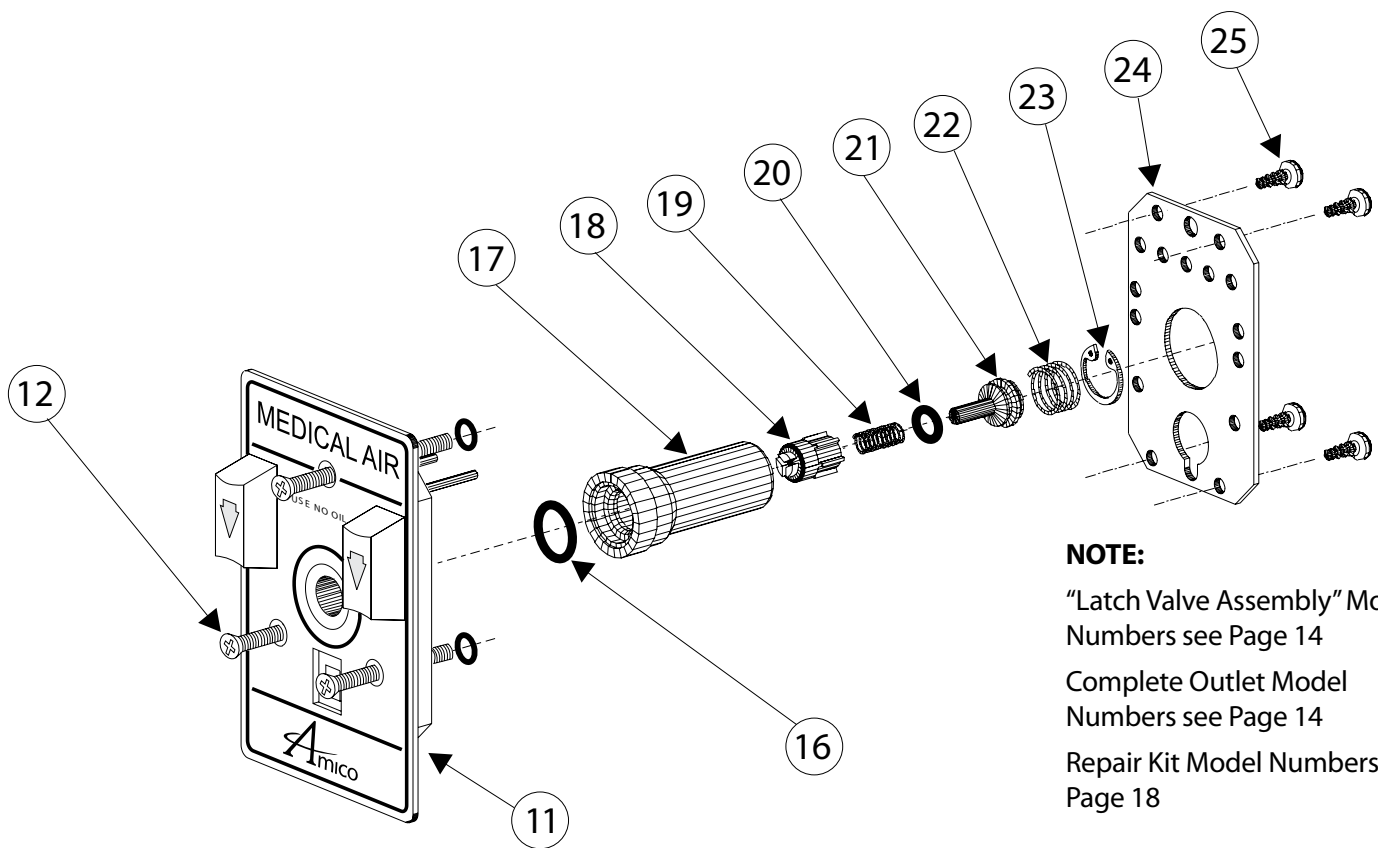

1. Unscrew the three retaining screws (12) until the "Latch Valve Assembly" (11) can be removed from the outlet.
2. Remove the four screws (25) holding the connector retaining plate (24) in place. Remove the plate.
3. Remove the connector (17) from the Valve Assembly.
4. Remove the connector O-Ring (16) from the front of the connector. Inspect the items for wear or damage and replace the O-Ring seal (16).
5. Remove the retaining ring (23) using appropriate pliers. Remove the dust cap (18), dust cap spring (19), O-Ring seal (20), primary check Valve (21) and spring (22). Inspect the items for wear or damage and replace if needed. Replace the O-Ring (20).
6. Re-install all internal components and lock in place with retaining ring (23). Insert the Connector (17) into the gas specific body. Check that the O-Ring (16) is in place. Re-install the connector retaining plate (24) and secure with four screws (25), do not overtighten.
7. Re-install the "Latch Valve Assembly" into the outlet. Coat the connector (17), with a thin coat of Oxygen compatible silicone lubricant to aid insertion. Tighten down the retaining screws (12), DO NOT over tighten, as this could damage the Latch Valve.
8. Connect a gas specific adapter into the outlet. The connection should be smooth and the adapter should lock and remain in place allowing gas to flow. If not replace the entire "Latch Valve Assembly" (11).

Latch Valve Assembly - Puritan-Bennett Compatible

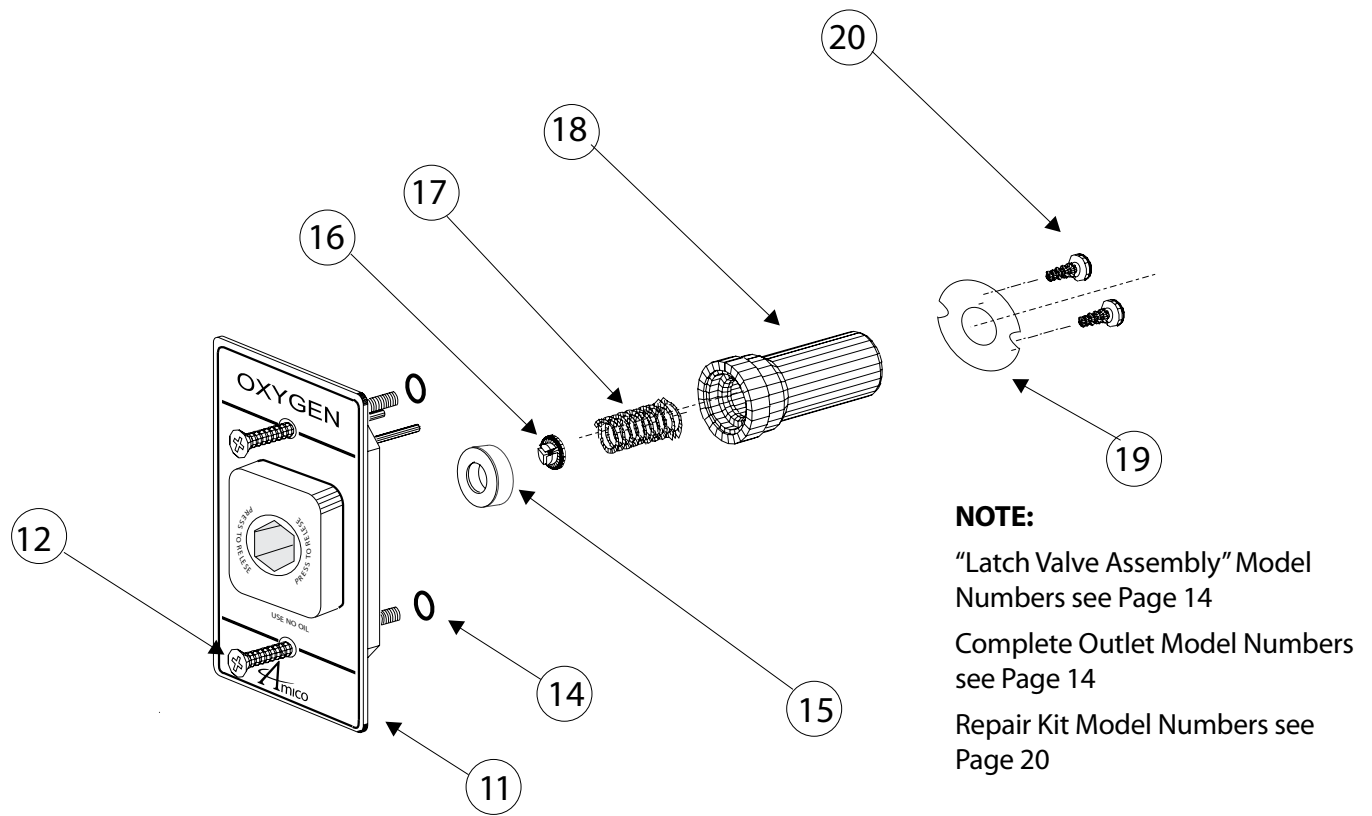

1. Unscrew the two retaining screws (12) until the "Latch Valve Assembly" (11) can be removed from the outlet.
2. Remove the two screws (20), holding the round retaining ring (19) in place. Remove the plate.
3. Remove the gas connector (18) from the Valve Assembly.
4. Remove the Body Seal (15) and Poppet (16) from the front of the Gas Connector (18). Inspect the items for wear or damage and replace the Body Seal (15).
5. Remove the Gas or Vacuum Spring (17), to inspect for wear or damage. Re-install the Gas or Vacuum Spring.
6. Re-install all internal components into the Gas Connector (18). Check that the Gas or Vacuum Spring (17), Body Seal (15) and Poppet (16) are in place. Re-install the round retaining plate (19) and secure with two screws (20), do not overtighten.
7. Re-install the "Latch Valve Assembly" into the outlet. Coat the connector (18) with a thin coat of Oxygen compatible silicone lubricant to aid insertion. Tighten down the retaining screws (12), DO NOT over tighten, as this could damage the Latch Valve.
8. Connect a gas specific adapter into the outlet. The connection should be smooth and the adapter should lock and remain in place allowing gas to flow. If not, replace the entire "Latch Valve Assembly" (11).

Latch Valve Assembly - Oxequip/MEDSTAR Compatible

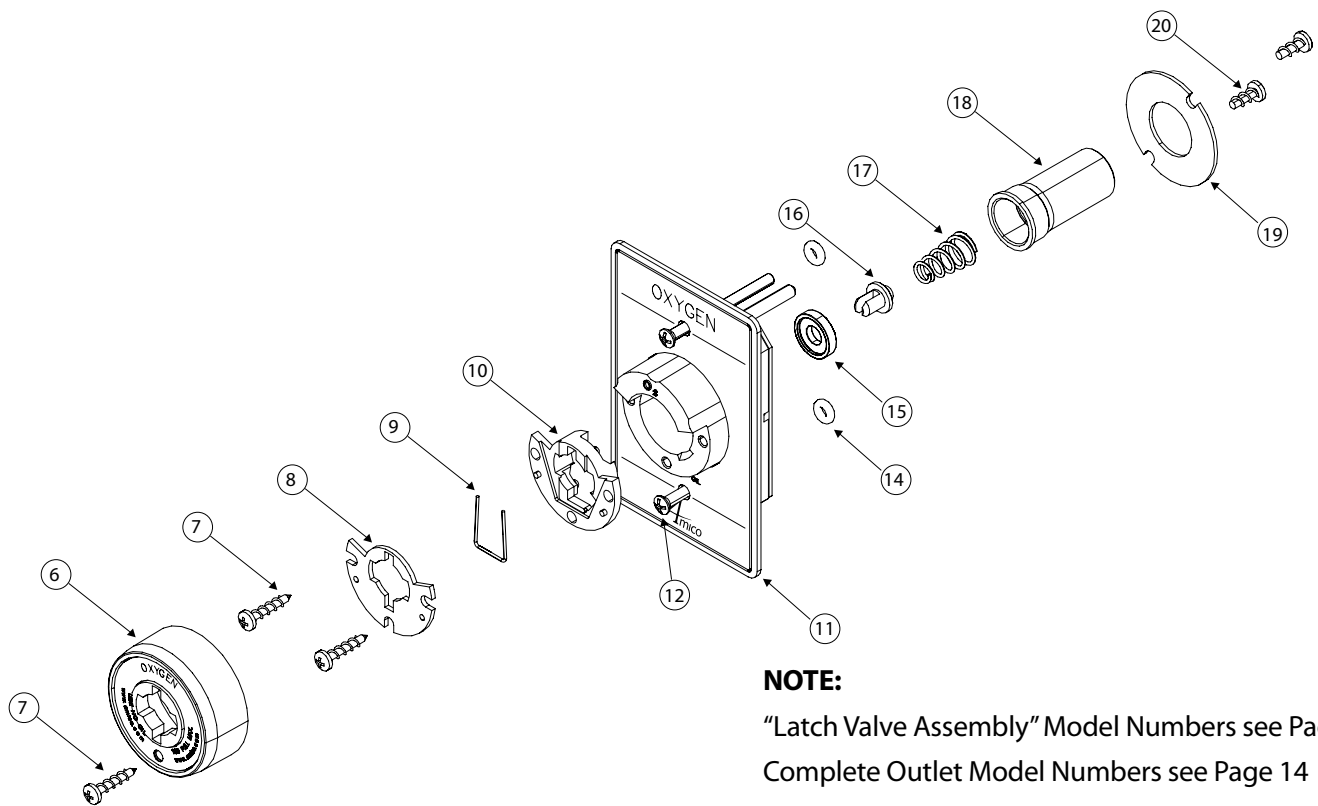

NOTE:

“Latch Valve Assembly” Model Numbers see Page 14
Complete Outlet Model Numbers see Page 14
Repair Kit Model Numbers see Page 21

1. Unscrew the two retaining screws (12) until the “Latch Valve Assembly” (11) can be removed from the outlet.
2. **Locking Mechanism Repair**
Unscrewing the first screw (7) and remove item (6). Then unscrew the second set of screws (7), this will give you access to items (8), (9) and (10). Inspect all three items for wear or damage, replace if needed.
3. **Outlet Gas Connector Repair**
While holding the round retaining ring (19) in place, remove the two screws (20). Remove the retaining ring (19) and gas connector (18). Then remove the Body Seal (15), the Poppet (16) and the Gas or Vacuum Spring (17). Inspect for wear or damage, replace components if needed.

Re-install the Gas or Vacuum Spring (17), the Poppet (16) and the Body Seal (15) into the gas connector (18). Re-install gas connector (18) and retaining plate (19), secure with two screws (20). DO NOT OVERTIGHTEN.
4. Re-install the “Latch Valve Assembly” into the outlet. Coat the connector (18) with a thin coat of Oxygen compatible silicone lubricant to aid insertion. Tighten down the retaining screws (12), DO NOT over tighten, as this could damage the Latch Valve.
5. Connect a gas specific adapter into the outlet. The connection should be smooth and the adapter should lock and remain in place allowing gas to flow. If not, replace the entire “Latch Valve Assembly” (11).

Rough-in Assembly

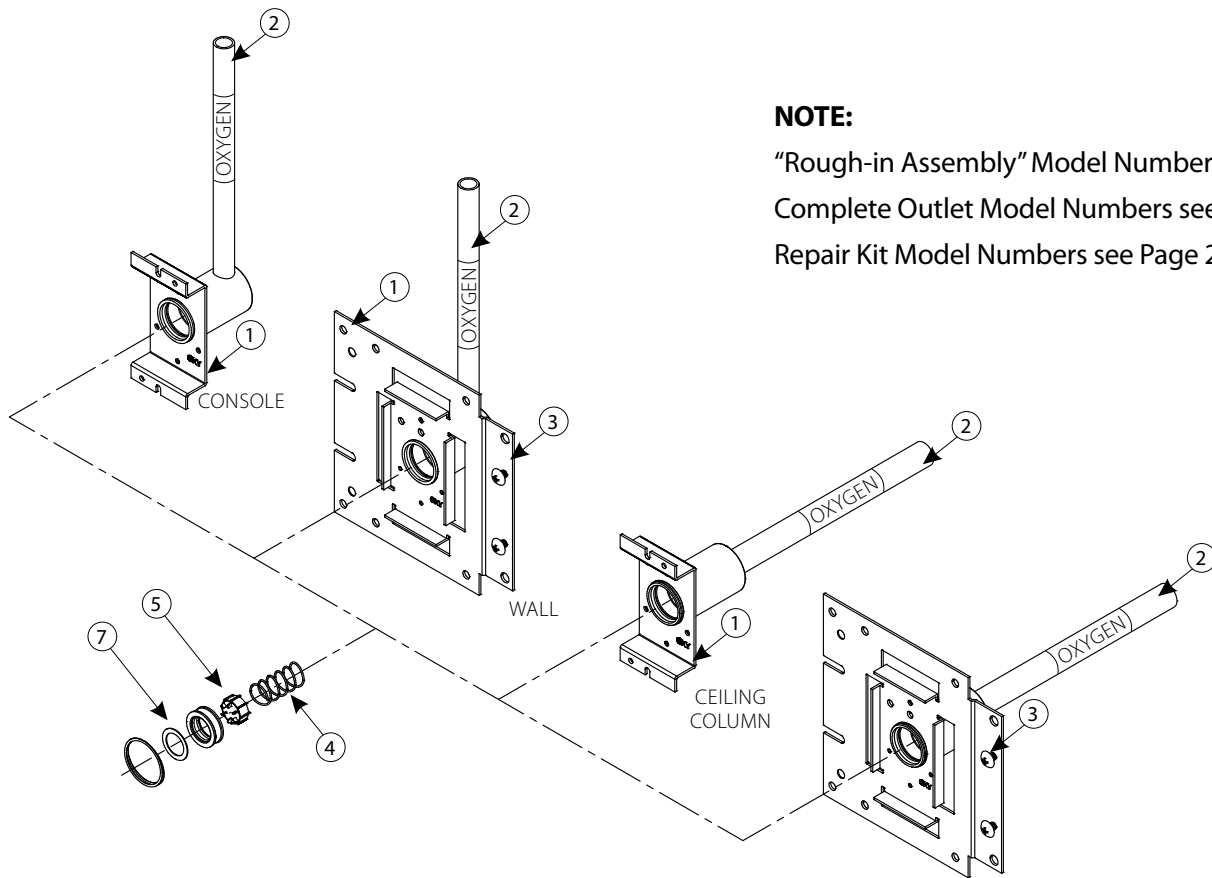

NOTE:

“Rough-in Assembly” Model Numbers see Page 15

Complete Outlet Model Numbers see Page 14

Repair Kit Model Numbers see Page 22



CAUTION: Ensure that the supply pressure is shut off before performing service.

Inside the “Rough-in Assembly” is a secondary check valve whose function is to shut off gas flow when the “Latch Valve Assembly” is removed. This seat/seal also prevents leakage around the latch valve connector. As the secondary seal is only a static seal, it will rarely need replacement. However, if the seat/seal does need replacement, follow the following procedure:

1. Ensure that no pressure exists in the line by depressing the secondary check valve (5).
2. Remove the retaining ring (8) from the inside of the outlet body. Use a small screwdriver to pull the end of the ring towards the center and then pull the ring up and out.
3. Remove the washer (7), seat/seal (6), secondary check valve (5) and secondary check valve spring (4). Inspect items for wear or damage and replace the seat/seal (6).
4. Re-install the spring (4), secondary check valve (5), seat/seal (6) and the washer (7). Insert the retaining ring (8) into the slot and ensure that the whole ring is seated properly.
5. Turn on the pressure and check for leaks. Re-install the “Latch Valve Assembly” and perform the inspection and test on page 1.

Model Numbers

Complete Assembly

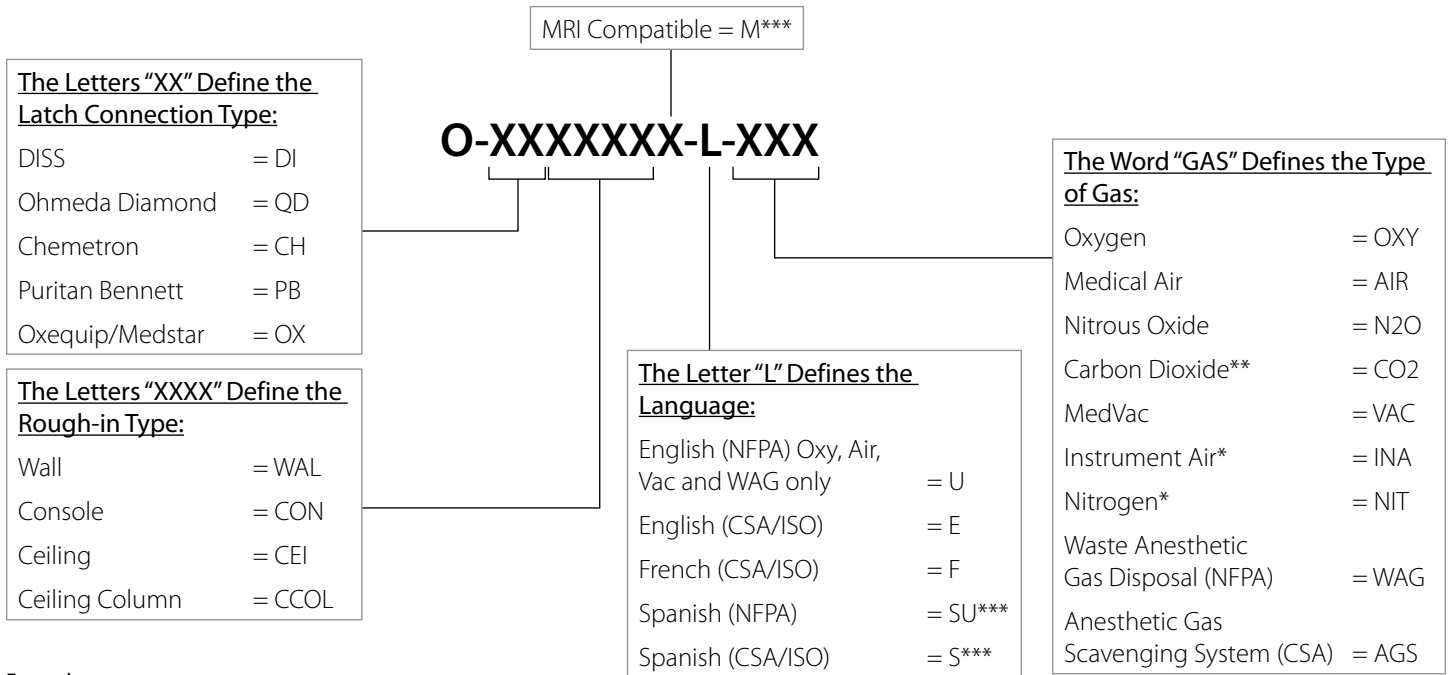

Example:
DISS Wall NFPA Oxygen Outlet = O-DISWAL-U-OXY

Latch Assembly

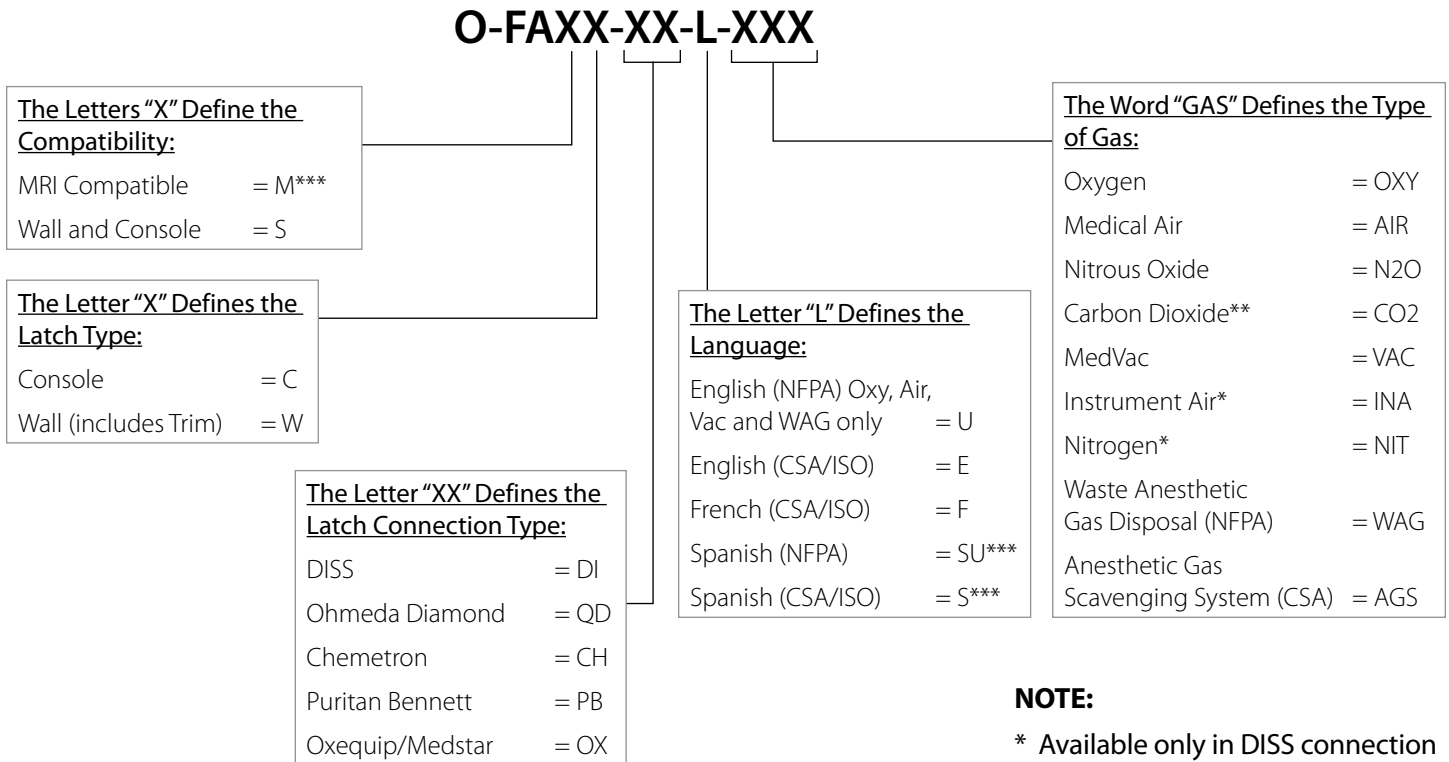

Example:
DISS Wall NFPA Oxygen Latch = O-FASC-DI-U-OXY.

NOTE:

- * Available only in DISS connection
- ** Not available in PB connection
- *** Some restrictions may apply

Model Numbers

Rough-in Assembly

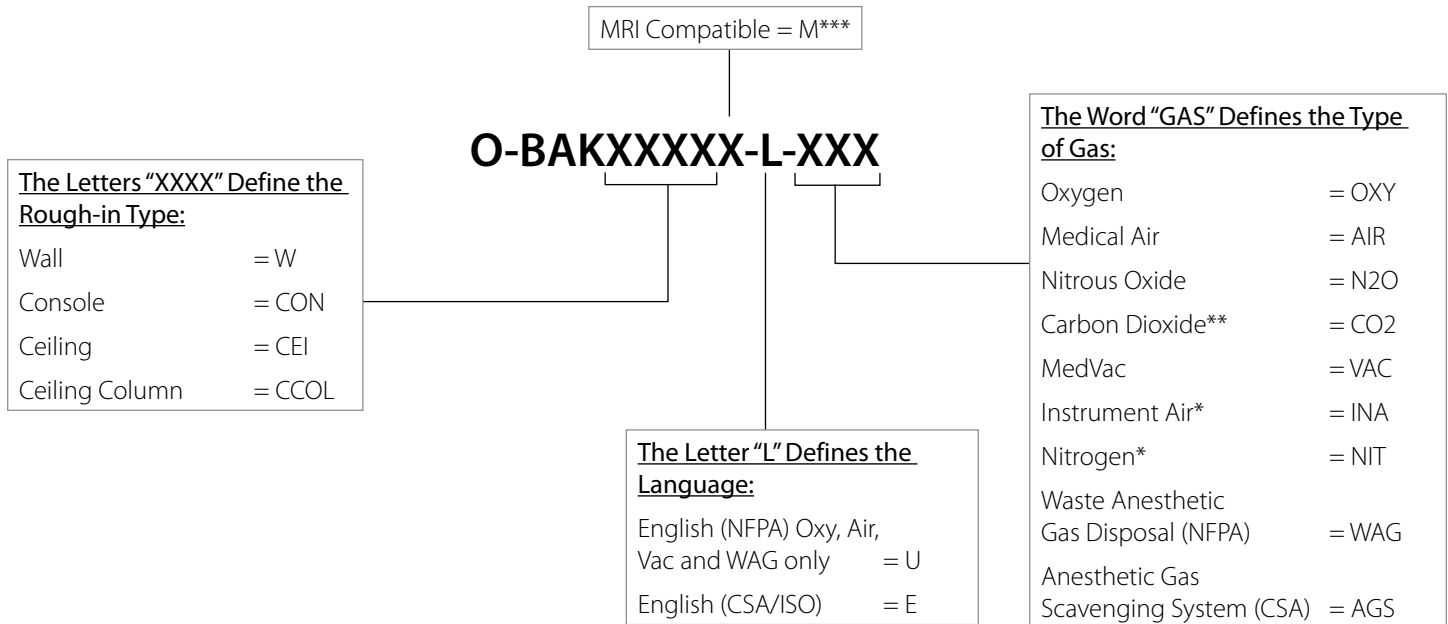

Example:
Wall NFPA Oxygen Rough-in = O-BAKW-U-OXY

NOTE:

* Available only in DISS connection

** Not available in PB connection

English NFPA rough-ins come with English and Spanish pipe labels

English CSA/ISO rough-ins come with English, Spanish and French pipe labels

Gas Indexing

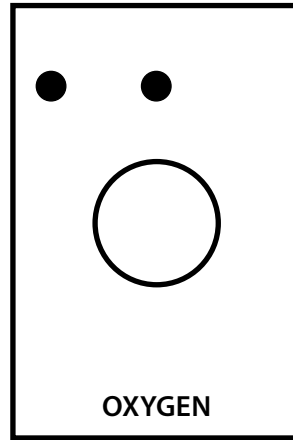
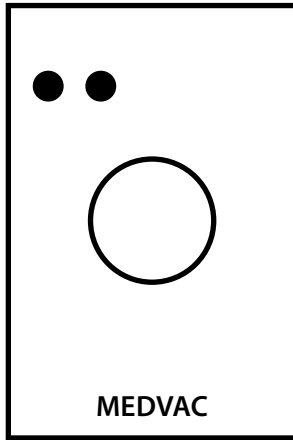

As seen from the front of the
"Rough-in Assemblies"

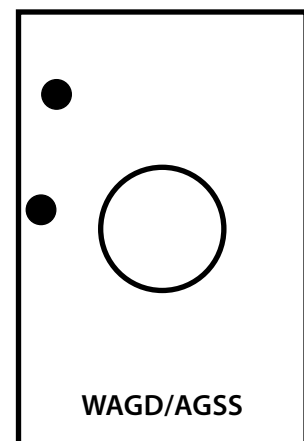
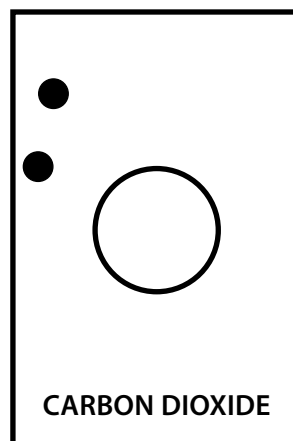
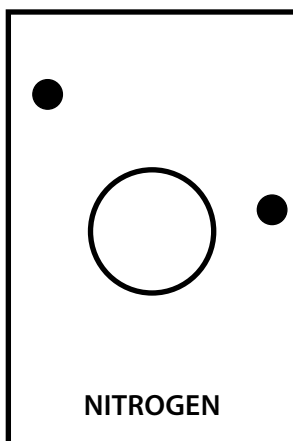
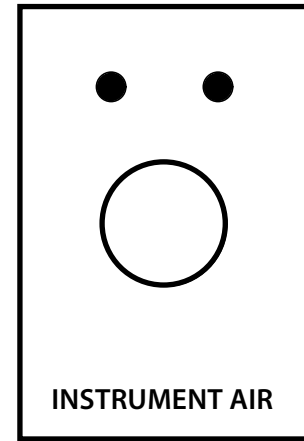
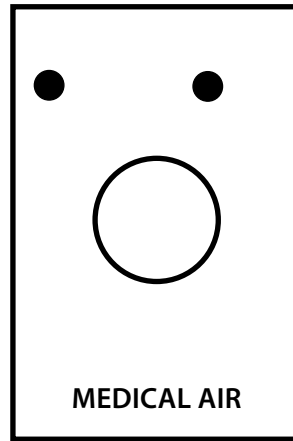
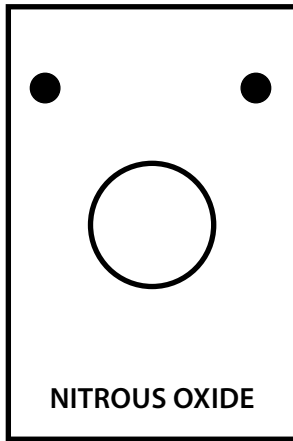

Replacement Components

Latch Valve Assembly - Ohmeda Compatible

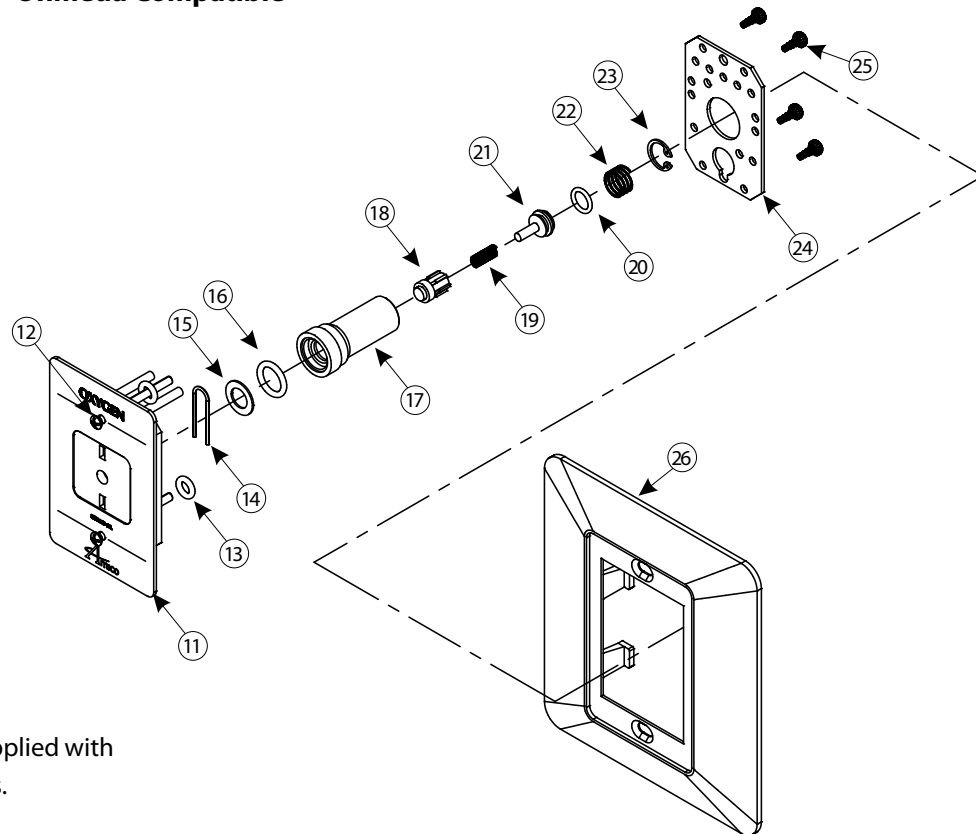

Chrome face plate not supplied with console or column outlets.

Item	Description
11	Ohmeda Latch Valve
12	Screw (2 required)
13	O-Ring (2 required)
14	Gas Connector U-Spring *
15	Flat Washer *
16	Gas Connector O-Ring *
17	Gas Connector
18	Primary Dust Cap
19	Primary Dust Cap Spring *
20	Primary Check Valve O-Ring *
21	Primary Check Valve *
22a	Primary Check Valve Spring *
22b	Primary Check Valve Spring-Vac *
23	C-Clip Primary Check Valve *
24	Connector Retaining Plate
25	Retaining Plate Screws (4 required)
26	Chrome Face Plate

Above parts with an * are found in repair kit: O-RK-LVA-QD, not sold individually.

Replacement Components

Latch Valve Assembly - Chemetron Compatible

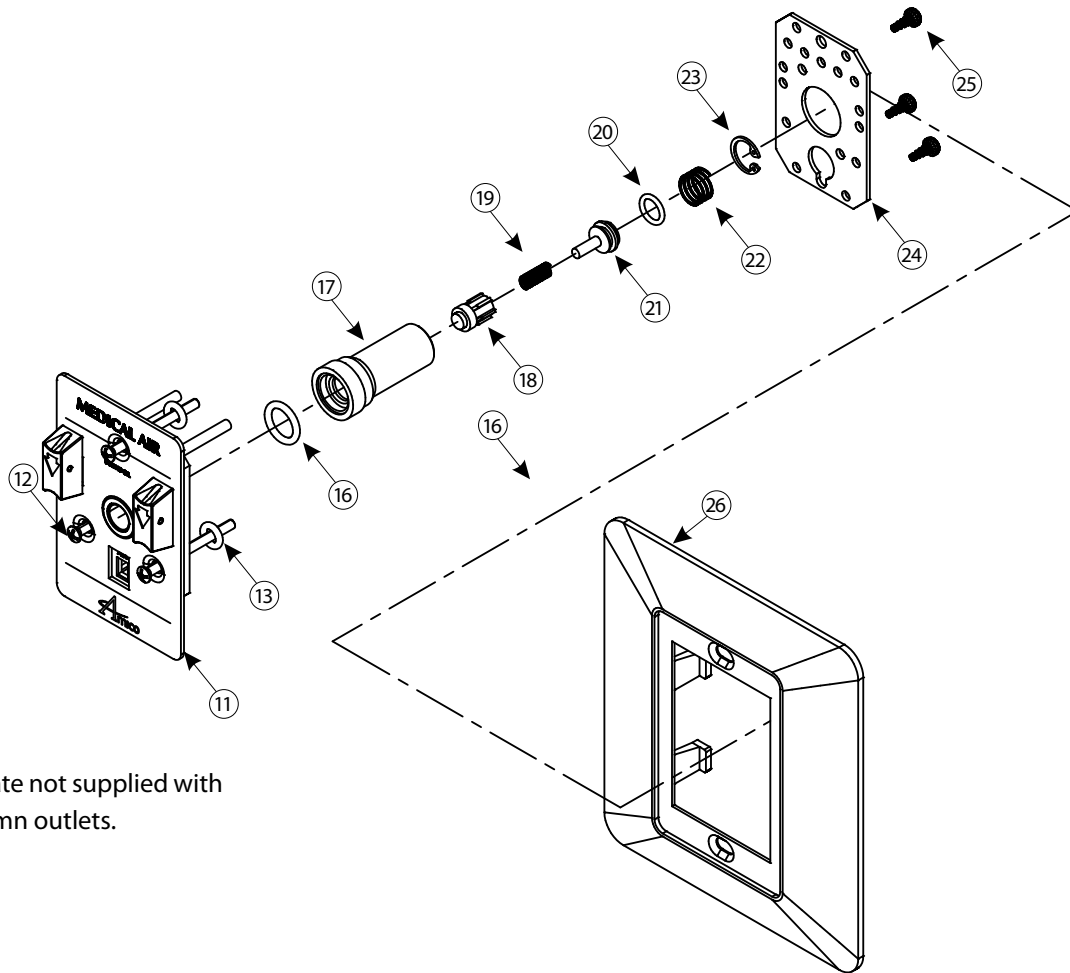

Chrome face plate not supplied with console or column outlets.

Item	Description
11	Chemetron Latch Valve
12	Screw (3 required)
13	O-Ring (3 required)
16	Gas Connector O-Ring *
17	Gas Connector
18	Primary Dust Cap
19	Primary Dust Cap Spring *
20	Primary Check Valve O-Ring *
21	Primary Check Valve *
22a	Primary Check Valve Spring *
22b	Primary Check Valve Spring-Vac *
23	C-clip Primary Check Valve *
24	Connector Retaining Plate
25	Retaining Plate Screws (4 required)
26	Chrome Face Plate

Above parts with an * are found in repair kit: O-RK-LVA-QD, not sold individually.

Replacement Components

Latch Valve Assembly - DISS

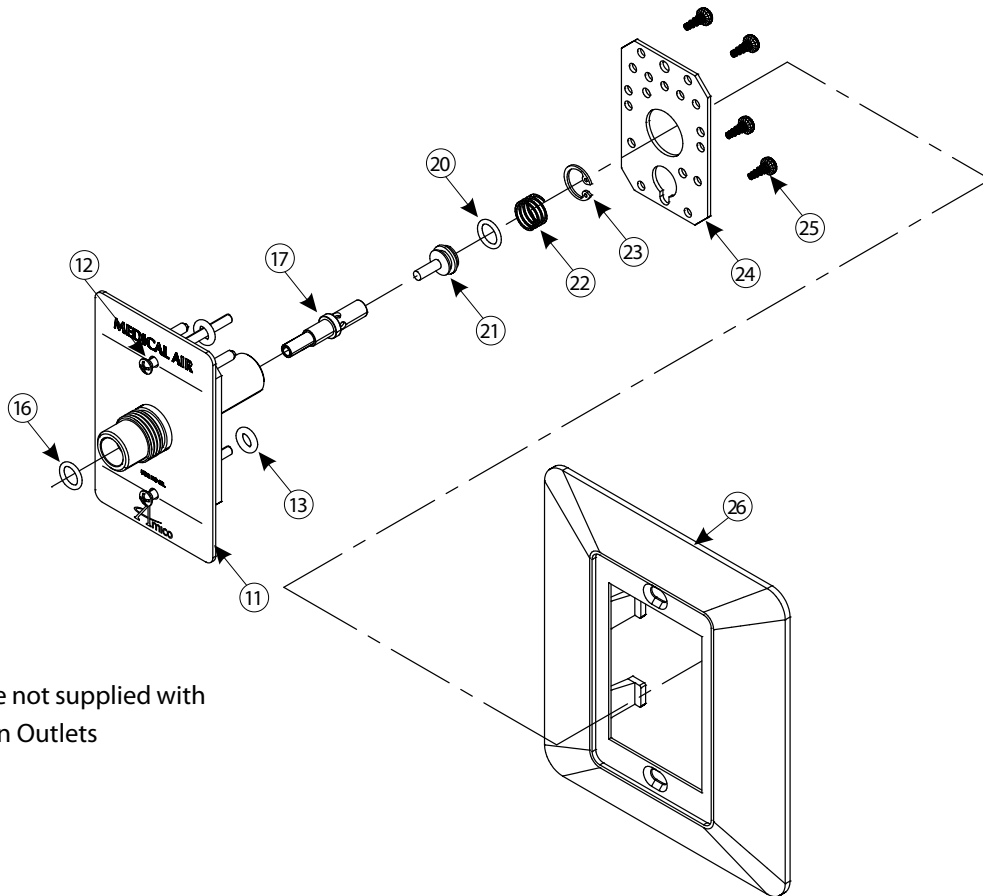

Chrome face plate not supplied with console or column Outlets

Item	Description
11	DISS Latch Valve
12	Screw (2 required)
13	O-Ring (2 required)
16a	Adapter O-Ring Nit *
16b	Adapter O-Ving Vac *
16c	Adapter O-Ring N2O *
17a	Valve Stem DISS Gas
17b	Valve Stem DISS Oxygen
17c	Valve Stem DISS Vac & WAGD/AGSS
20	Primary Check Valve O-Ring *
21	Primary Check Valve *
22	Primary Check Valve Spring *
23	C-clip Primary Check Valve *
24	Connector Retaining Plate
25	Retaining Plate Rivets (non-removable)
26	Chrome Face Plate

Above parts with an * are found in repair kit: O-RK-LVA-DIS, not sold individually.

Replacement Components

Latch Valve Assembly - Puritan-Bennett Compatible

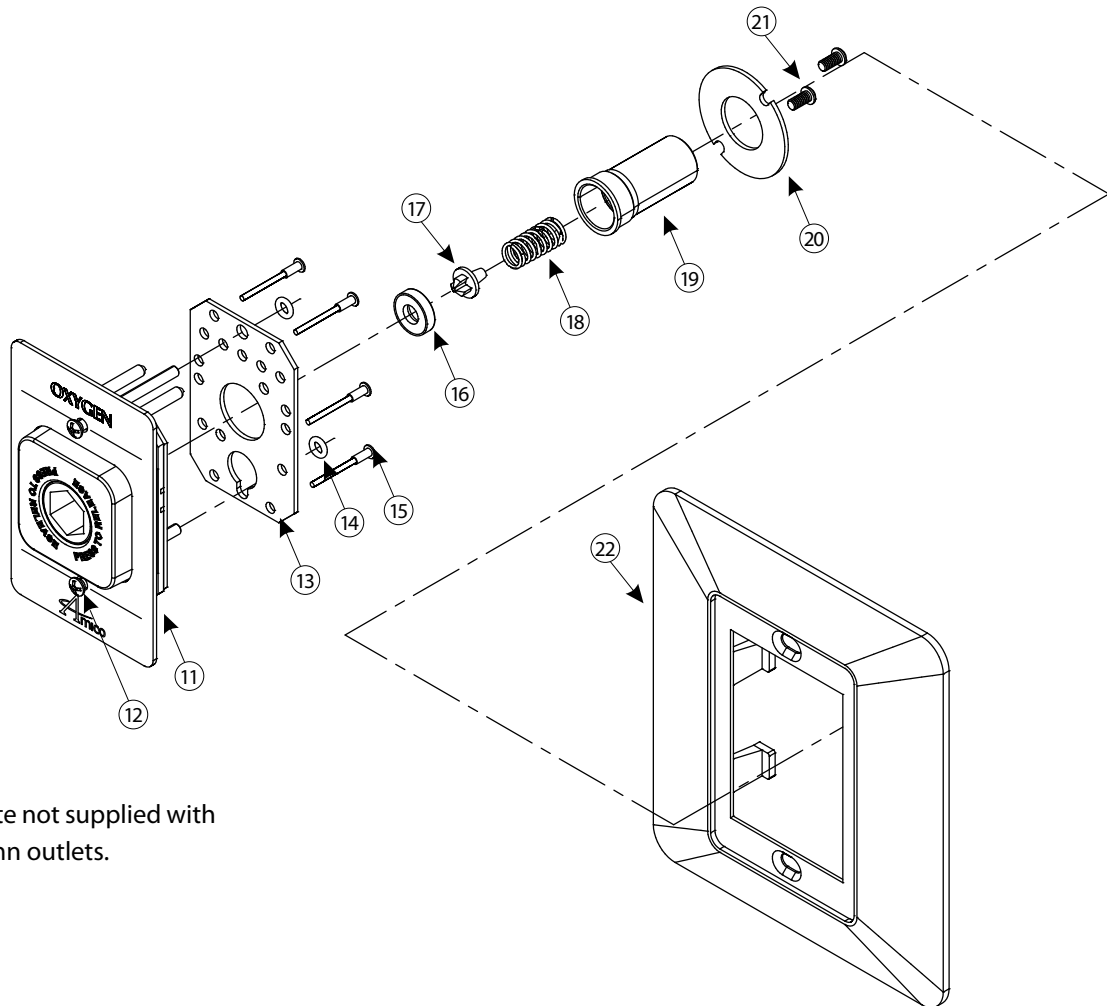

Chrome face plate not supplied with console or column outlets.

Item	Description
11	Puritan-Bennett Latch Valve
12	Mounting Screw (2 required)
13	Connector Retaining Plate
14	O-Ring (2 required)
15	Retaining Plate Rivets (non-removable)
16	Body Seal *
17	Poppet for Body *
18a	Spring For All Gases (expect vac)*
18b	Spring For Vacuum*
19	Gas Connector
20	Connector Retaining Washer
21	Retaining Washer Screws (2 required)
22	Chrome Face Plate

Above parts with an * are found in repair kit: O-RK-LVA-PB, not sold individually.

Replacement Components

Latch Valve Assembly - Oxequip/MEDSTAR Compatible

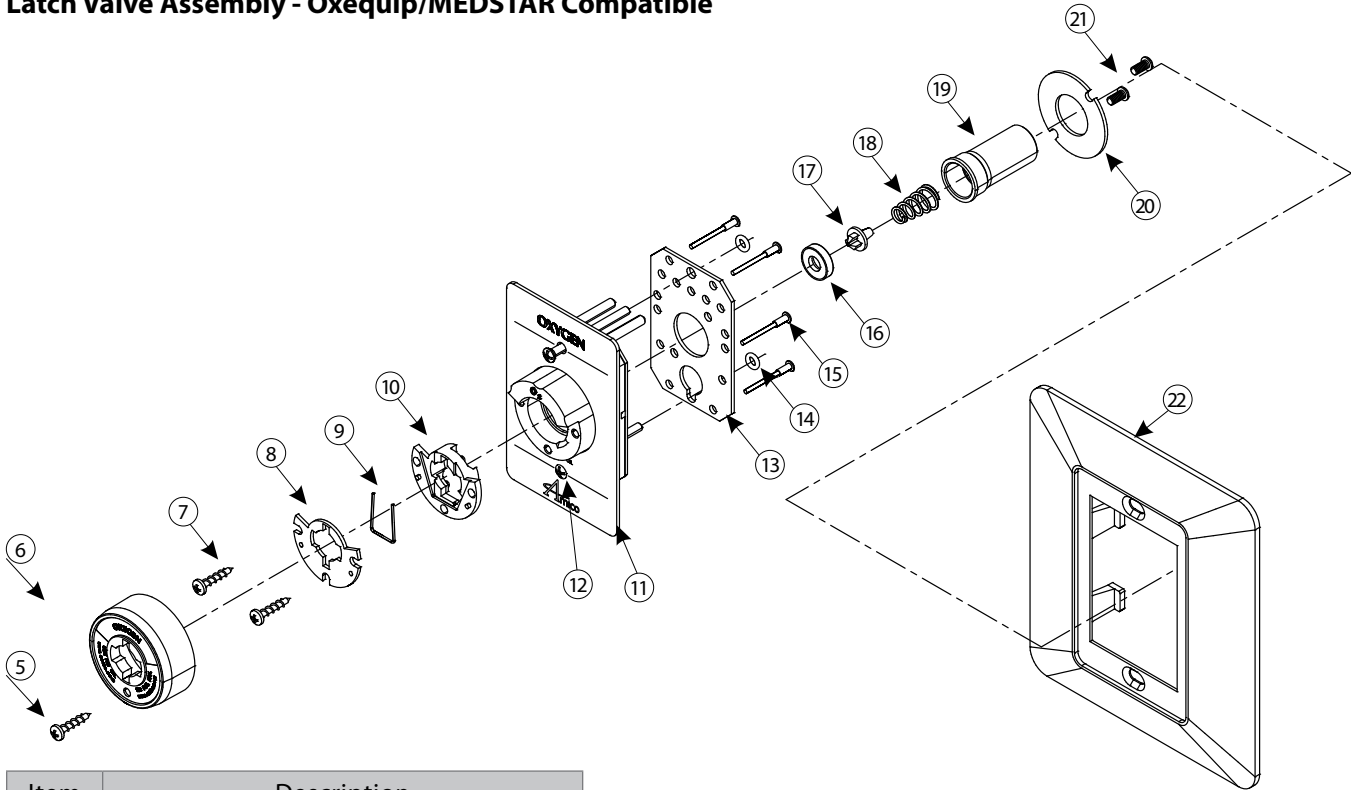

Item	Description
5	#6 x 1/2" (12.7 mm) Screws
6	Plastic Trimcap
7	#6 x 5/8" (15.9 mm) Screws
8	Cover Guide Plate **
9	U-Spring **
10	Cam Guide Plate **
11	Oxequip Latch Valve
12	Mounting Screw (2 required)
13	Connector Retaining Plate
14	O-Ring (2 required)
15	Retaining Plate Rivets (non-removable)
16	Body Seal *
17	Poppet For Body *
18a	Spring For All Gases (except vac) *
18b	Spring For Vacuum *
19	Gas Connector
20	Retaining Washer
21	Retaining Washer Screws (2 required)
22	Chrome Face Plate

Above parts with * are found in repair kit: O-RK-LVA-OX-GC, not sold individually.

Above parts with ** are found in repair kit: O-RK-LVA-OX-LM, not sold individually.

Both O-RK-LVA-OX-GC and O-RK-LVA-OX-LM can be ordered as one kit using O-RK-LVA-OX.

Replacement Components

Rough-in Assembly

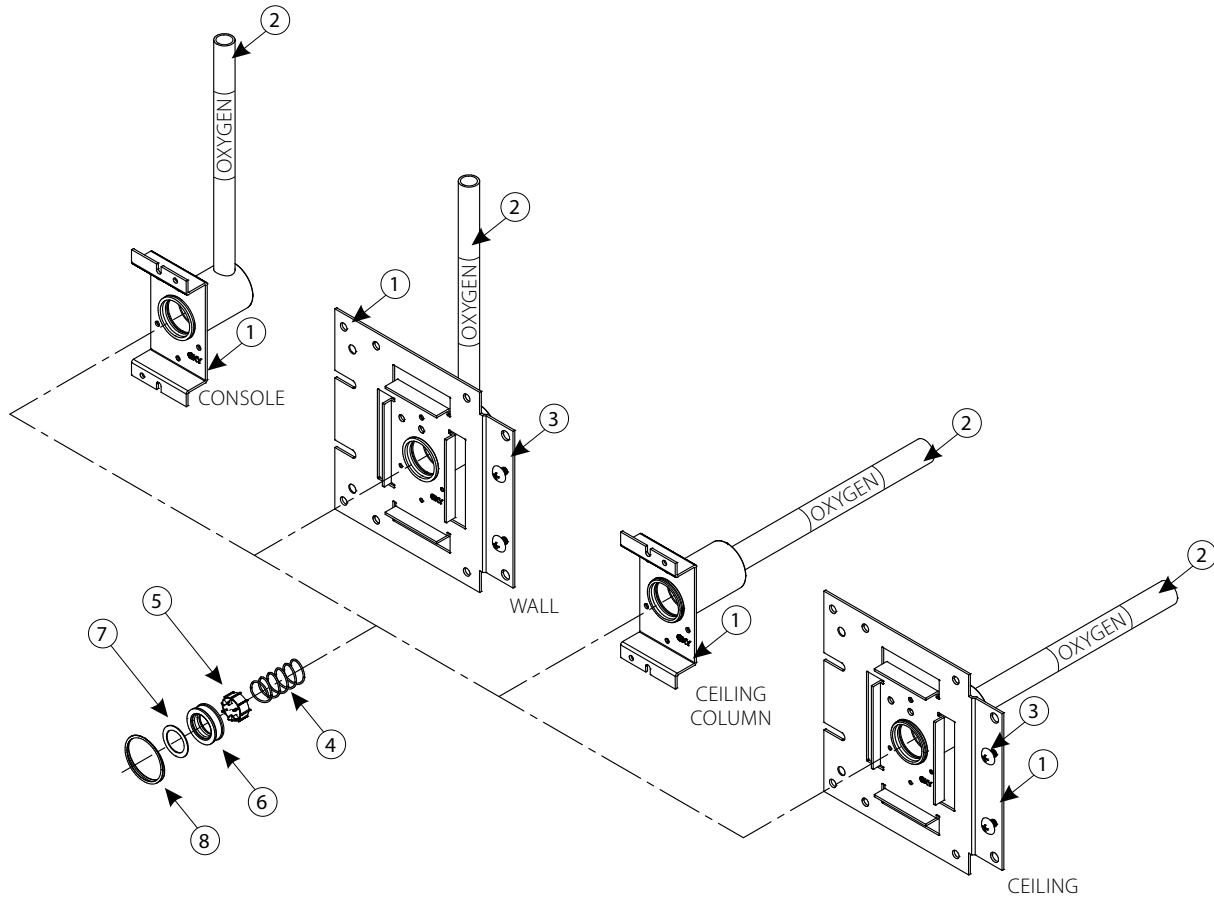

Item	Description
1	Rough-in Assembly
2	Gas Label **
3	Screw (2 required wall and ceiling only)
4	Secondary Check Valve Spring *
5	Secondary Check Valve *
6	Seat/Seal *
7	Washer *
8	Retaining Ring *

Above parts with an * are found in repair kit: O-RK-BAK, not sold individually.

Notes

BROWARD **A&C**
MEDICAL GAS SPECIALISTS

954-725-1470 Ext. 403

