

PSA Oxygen Generator Centrox



PSA Generator Module



Air Compressor Module

The Centrox is an oxygen generator ideal for use in many applications. The Centrox's ability to deliver up to 95% oxygen concentration at flows of up to 32 SCFH (0.84 Nm³/hr or 15 LPM) make it a great fit for commercial uses requiring up to 50 psig (345 kPa or 3.5 barg).

Features

- Self-contained (internal air compressors)
- Microprocessor controlled
- Low operating cost
- Automatic and unattended operation
- Wall or rack mount design
- Heavy duty metal enclosures
- Oxygen concentration monitor

Typical Applications

- Brazing/Soldering
- Environmental Remediation
- Fish Farming
- Glass Work/Blowing
- Ozone (Generator) Feed Gas
- Veterinary Medicine

Specifications

Product Flow ¹	32 SCFH (0.84 Nm ³ /hr or 15 LPM)
Product Pressure	50 psig (345 kPa or 3.5 barg)
Product Concentration	Up to 95%
Product Dew Point	-100°F (-73°C)
Dimensions (W x D x H) (Nominal)	
■ Air Compressor Module	21 x 13 x 27 in (52 x 32 x 68 cm)
■ PSA Generator Module	27 x 15 x 38 in (68 x 37 x 97 cm)
Weight	
■ Air Compressor Module	100 lb (45 kg)
■ PSA Generator Module	160 lb (73 kg)
Physical Connection	
Product Gas Outlet	B size oxygen demand valve
Ambient Operating Conditions	Locate the oxygen generator in a well-ventilated area that is protected from weather elements and remains between 40°F (4°C) and 112°F (44°C)
Control Power Requirements (Single Phase)	120 V ~ ±10%, 60 Hz, 11.0 A
NRTL Certifications and Approvals	CAN/CSA-C22.2 No. 60601-1:08, AAMI ES60601-1, EN 60601-1-2: 2015/IEC 60601-1-2: 4th Edition, CISPR 11:2009 + A1:2010 / EN 55011:2009 +A1:2010

60 Gallon Oxygen Receiver

Dimensions (Dia. x H)	26 x 52 in (65 x 131 cm)
Weight	159 lb (72 kg)

¹ SCF (Standard cubic foot) gas measured at 1 atmosphere and 70°F / Nm³ (Normal cubic meter) gas measured at 1 atmosphere and 0°C / LPM (Liters per minute) gas measured at 1 atmosphere and 21°C

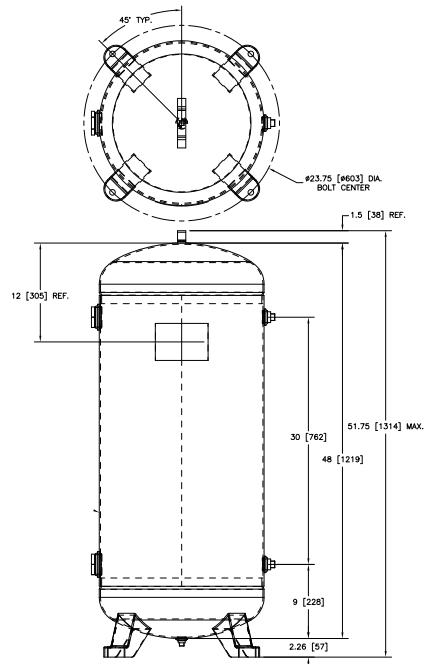
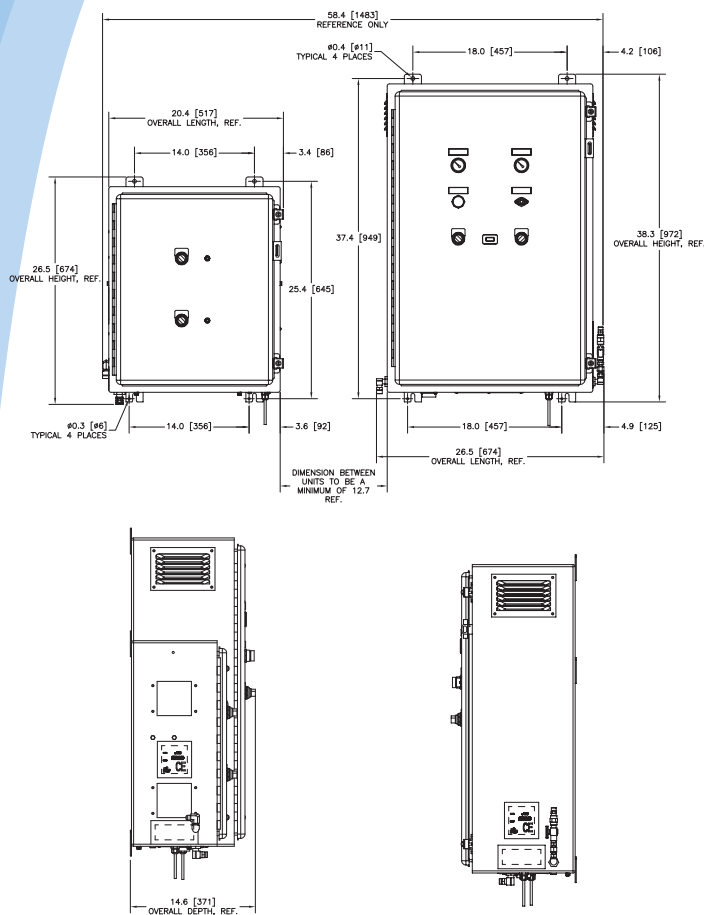

60 Gallon Receiver

Note: All dimensions are nominal.

Ordering Information

Model	Part Number	Description
Centrox ¹	AS074-1	120 V ~ ±10%, 60 Hz with oxygen concentration monitor (LED indicator)
Required Accessories	TA150-1	60 Gallon Oxygen Receiver
	KI046-1	Accessory Kit (10 ft Stainless Braided Oxygen Hose & Primary/Secondary Oxygen Ball Valve Assembly)
	KI470-1	Accessory Kit (10 ft Stainless Braided Oxygen Hose & Regulator Assembly with Flowmeter)
Optional Accessories	KI225-1	Accessory Starter Kit
	TA212-1	Accessory Kit, Mini Oxygen Receiver
	AN021-1	Oxygen Analyzer (Maxtec Handi)
	AN005-1	Oxygen Analyzer (Maxtec Max O ₂ Plus)
	AN075-1	Oxygen Analyzer/Sensor (Maxtec Max O ₂ Plus)

Shipping Information	Centrox	60 Gallon Oxygen Receiver
Class	92.5	70
Commodity Classification Number	8421.39.8040	7311.00.0000
Dimensions (W x D x H)	34 x 52 x 50 in (86 x 132 x 127 cm) with Accessory Kits, Crated	28 x 30 x 56 in (71 x 76 x 142 cm)
Gross Weight	559 lb (254 kg) with Accessory Kits, Crated	177 lb (80 kg)

Warranty: 1 Year Parts and Factory Labor*

* An unprotected or inadequately ventilated environment, or improper control power may cause damage to the oxygen generator not covered under warranty.

¹ Interconnecting red compressed air hose included.

All performance ratings based on an ambient temperature up to 100°F (38°C), up to 1,000 feet elevation, and 80% relative humidity.



© 2020 AirSep Corporation. All Rights Reserved.
AirSep reserves the right to discontinue its products, or change the prices, materials, equipment, quality, descriptions, specifications and/or processes to its products at any time without prior notice and with no further obligation or consequence. Any rights expressly stated herein are reserved by us, as applicable.



1533 SW 1st Way, Suite F19
Deerfield Beach, FL 33441
Office: 954-725-1470
Email: orders@medicalgassupplier.com