

PSA Oxygen Generator

AS-G



AirSep Alpha Series Oxygen Generators produce from 20 to 5,500 cubic feet of oxygen per hour at up to 95% oxygen concentration. When electricity and a source of compressed air is supplied, these dependable machines can provide oxygen for practically any application.

Features

- Produces oxygen from an independent compressed air source
- Microprocessor controlled
- Low operating cost
- Automatic and unattended operation
- Easy to install and maintain
- NEMA 4 Touchscreen control panel with integrated oxygen concentration monitor (available on some models)

Typical Applications

- Cutting/Brazing/Soldering
- Environmental Remediation
- Fish Farming
- Glass Work/Blowing
- Ozone (Generator) Feed Gas
- Thermal/Chemical Oxidation
- Waste/Water Treatment

Specifications

Product Flow	250 – 320 SCFH (6.57 – 8.41 Nm ³ /hr or 117 – 151 SLPM) ¹
Product Pressure	45 – 65 psig (310 – 448 kPa or 3.0 – 4.4 barg) ¹
Product Concentration	Up to 95%
Product Dew Point	-100°F (-73°C)
Dimensions (W x D x H) (Nominal)	36 x 29 x 75 in (91 x 74 x 191 cm)
Weight	956 lb (434 kg)
Physical Connections ²	
Compressed Air Inlet	¾" FNPT
Product Gas Outlet	¾" FNPT
Ambient Operating Conditions	Locate the oxygen generator in a well-ventilated area that is protected from weather elements and remains between 40°F (4°C) and 104°F (40°C)
Storage	
Temperature	-13°F (-25°C) to 131°F (55°C)
Humidity	0-90% (non-condensing)
Feed Air Requirements	Flow Rate: <i>Refer to chart on reverse page.</i> Clean and Dry "Plant Air" (Class 5.6.4 per ISO 8573.1) Pressure: 90 psig (621 kPa or 6.2 barg) minimum Temperature: 122°F (50°C) maximum
Control Power Requirements (Single Phase)	120 V ~ ±10%, 50/60 Hz, 3.0 A or 220 V ~ ±10%, 50/60 Hz, 1.0 A
NRTL Certifications and Approvals	China Pressure Vessel, ASME Section VIII Division 1, CAN/CSA-C22.2 No. 61010-1-12, ANSI/UL Std. No. 61010-1:2012 (for 120 V configurations only)
120 Gallon Oxygen Receiver	
Dimensions (Dia. x H)	24 x 79 in (61 x 199 cm)
Weight	282 lb (128 kg)

¹ SCF (Standard cubic foot) gas measured at 1 atmosphere and 70°F (21°C) / Nm³ (Normal cubic meter) gas measured at 1 atmosphere and 32°F (0°C) / SLPM (Standard liters per minute) gas measured at 1 atmosphere and 70°F (21°C)

² Hose and applicable adapters included with optional Factory-supplied accessory kits.

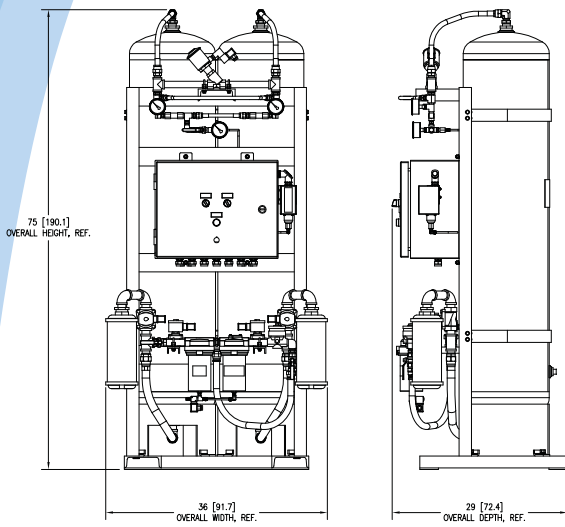

Note: All dimensions are nominal.

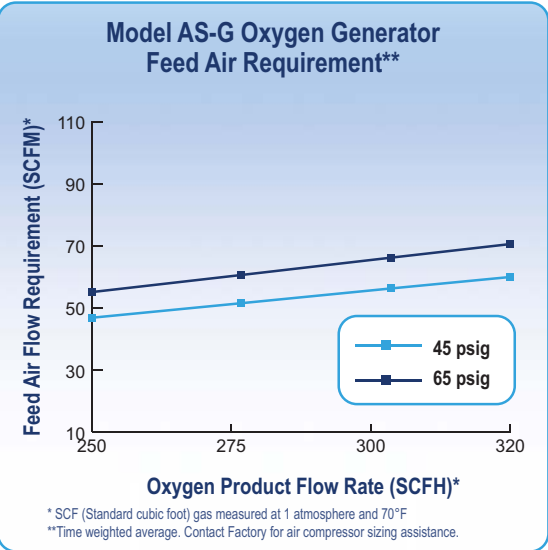

Ordering Information

Model	Part Number	Description	
AS-G	AS104-1	120 V ~ ±10%, 50/60 Hz ¹	
	AS104-2	220 V ~ ±10%, 50/60 Hz ¹	
	AS104-3	With NEMA 4 Pressure Switch, 120 V ~ ±10%, 50/60 Hz ¹	
	AS104-4	With NEMA 4 Pressure Switch, 220 V ~ ±10%, 50/60 Hz ¹	
	AS104-7	With HMI NEMA 4 Touchscreen and oxygen concentration monitor, 120 V ~ ±10%, 50/60 Hz ¹	
	AS104-8	With HMI NEMA 4 Touchscreen and oxygen concentration monitor, 220 V ~ ±10%, 50/60 Hz ¹	
	AS104-9	With CE Approved Vessels, 220 V ~ ±10%, 50/60 Hz ¹	
	AS104-10	With NEMA 4 Pressure Switch/ Local Remote ON/OFF, 120 V ~ ±10%, 50/60 Hz ¹	
	AS104-11	With NEMA 4 Pressure Switch/ Local Remote ON/OFF, 220 V ~ ±10%, 50/60 Hz ¹	
	AS104-12	With oxygen concentration monitor (LED indicator), 120 V ~ ±10%, 50/60 Hz ¹	
	AS104-13	With oxygen concentration monitor (LED indicator), 220 V ~ ±10%, 50/60 Hz ¹	
	AS104-16	With China Approved Vessels, 220 V ~ ±10%, 50/60 Hz ¹	
	Required Accessories	TA151-1	120 Gallon Oxygen Receiver
		KI413-1	Accessory Kit (interconnecting hoses/fittings and oxygen regulator)
		KI413-2	Accessory Kit (HMI, interconnecting hoses/fittings, oxygen regulator and oxygen filter)
KI413-3		Accessory Kit (HMI, interconnecting hoses/fittings, isolation valve with oxygen regulator and oxygen filter)	
Optional Accessories	KI476-1	Accessory Kit (10 ft stainless braided oxygen hose - from oxygen regulator to use point)	
	KI404-3	Accessory Kit (manual switch-over manifold for cylinder backup)	
	KI375-4	Carbon Filter Add-On Kit	
	AN021-1	Oxygen Analyzer (Maxtec Handi)	
	AN005-1	Oxygen Analyzer (Maxtec Max O ₂ Plus)	
AN075-1	Oxygen Analyzer/Sensor (Maxtec Max O ₂ Plus)		

Shipping Information	AS-G	120 Gallon Oxygen Receiver
Class	92.5	70
Commodity Classification Number	8421.39.8040	7311.00.0000
Dimensions (L x W x H)	41 x 34 x 85 in (104 x 86 x 216 cm) with Accessory Kit(s), Crated 41 x 34 x 85 in (104 x 86 x 216 cm) Horizontal 86 x 41 x 38 in (218 x 104 x 97 cm) with Accessory Kit(s) and CE Beds, Crated	40 x 40 x 85 in (102 x 102 x 216 cm)
Approximate Gross Weight	1,160 lb (526 kg) with Accessory Kit(s), Crated 1,205 lb (547 kg) with Accessory Kit(s) and CE Beds, Crated 1,303 lb (591 kg) Horizontal	354 lb (161 kg)

Warranty: 1 Year Parts and Factory Labor***

*** An unprotected or inadequately ventilated environment, or improper control power may cause damage to the oxygen generator not covered under warranty.

¹ Specify oxygen flow and pressure at time of order.

All performance ratings based on an ambient temperature up to 100°F (38°C), up to 1,000 feet elevation, and 80% relative humidity.



© 2021 AirSep Corporation. All Rights Reserved.
 AirSep reserves the right to discontinue its products, or change the prices, materials, equipment, quality, descriptions, specifications and/or processes to its products at any time without prior notice and with no further obligation or consequence. Any rights expressly stated herein are reserved by us, as applicable.



1533 SW 1st Way, Suite F19
 Deerfield Beach, FL 33441
 Office: 954-725-1470
 Email: orders@medicalgassupplier.com